

## General Description

The EB1612RK-GGB is a receiving module that supports Dual-Band&Multi-Mode. It has built-in highly integrated GNSS receiver chip, supports multi band and multi system cm4f (main frequency 350mhz, 22nm Technology) chip of Third-generation Beidou Navigation Satellite System (BDS-3). Besides, it is capable of tracking all global civil navigation systems (BDS,GPS, Glonass,Galileo,QZSS,IRNSS and SBAS) in all bands.

EB1612RK-GGB module is based on the state of art BDS-3 architecture, integrating multi-band and multi-system GNSS RF and base band. This newly designed architecture makes this single chip achieve sub-meter level position accuracy without correction data from ground-based augmentation station and higher sensitivity, greater for improved jam resistance and multi-path, provide a highly robust service in complicated environment.

EB1612RK-GGB module contains BK1662 positioning engine inside, featuring high sensitivity, low power consumption, and fast TTFF. The superior cold start sensitivity allows it to acquire, track, and get position fix autonomously in difficult weak signal environment. The receiver's superior tracking sensitivity allows continuous position coverage in nearly all outdoor application environments. The high performance signal parameter search engine is capable of testing 16 million time-frequency hypotheses per second, offering superior signal acquisition and TTFF speed.

## Applications

- LBS (Location Based Service)
- PND (Portable Navigation Device)
- Vehicle navigation system
- Mobile phone



**Figure 1: EB1612RK-GGB Top View**

## Features

- Build on high performance, low-power BK1662 chip set
- Ultra high Tracking sensitivity: -165dBm
- Concurrent reception of dual-band and multi-system satellite signals
- Supports RTK ; Protocol: RTCM 3.3
- Supports all civil GNSS signals
- Supports BDS-3 signal
- Extremely fast TTFF at low signal level
- Multi-path detection and suppression
- Works with passive and active antenna
- Low power consumption: Max 28 mA@3.3V
- NMEA-0183 compliant protocol or custom protocol
- Operating voltage:2.8V to 3.6V
- SMD type with stamp holes
- Small form factor: 16x12x2.6mm
- Operating temperature -40 ~ +85°C
- RoHS compliant (Lead-free)

# 1. Functional Description

## 1.1. Key Features

**Table 1: Firmware Version & NMEA messages**

Item	Specification
Firmware Version	• /
NMEA Messages	• \$GNRMC,\$GNGLL,\$GNGGA,\$GPGSV,\$BDGSV,\$GDLGSV,\$GAGSV,\$IRGSV,\$GNVTG,\$GNGSA

**Table 2: Key Features**

Parameter	Specification
GNSS engine	• 200 tracking channels with fast search engine
GNSS reception	<ul style="list-style-type: none"> <li>• GPS/QZSS: L1,L5</li> <li>• GLONASS: L1</li> <li>• GALILEO: E1,E5</li> <li>• BEIDOU: B1I,B1C, B2A</li> <li>• INRSS: L5</li> <li>• SBAS: WAAS, EGNOS, MSAS, GAGAN</li> </ul>
Update rate	<ul style="list-style-type: none"> <li>• GNSS: 20Hz Maximum,1Hz by default</li> <li>• RTK: 10Hz Maximum,1Hz by default</li> </ul>
Position accuracy	<ul style="list-style-type: none"> <li>• GNSS: 1m CEP</li> <li>• RTK: 1cm+1ppm (CEP50)</li> </ul>
Velocity & Time accuracy	<ul style="list-style-type: none"> <li>• GNSS: 0.01m/s CEP</li> <li>• SBAS: 0.05 m/s</li> <li>• 1PPS: 20 ns</li> </ul>
Time to First Fix(TTFF)	<ul style="list-style-type: none"> <li>• Hot start: 5 s</li> <li>• Cold start : 28 s</li> <li>• AGPS: 1.5s</li> <li>• RTK initialization time: ≤10s</li> <li>• RTK Re-acquisition time: &lt;2s</li> </ul>
Sensitivity	<ul style="list-style-type: none"> <li>• Cold start: -148dBm</li> <li>• Hot start: -165dBm</li> <li>• Re-acquisition: -159dBm</li> <li>• Tracking &amp; navigation: -165dBm</li> </ul>
GNSS Operating limit	<ul style="list-style-type: none"> <li>• Velocity: 515m/s</li> <li>• Altitude: 18000m</li> </ul>
Datum	• Default WGS-84, User definable
UART Port	<ul style="list-style-type: none"> <li>• UART Port: TXD and RXD</li> <li>• Supports baud rate : 9600 , 38400 , 115200 , 230400 , 460800 , 1000000 , 2000000, 115200bps by default.</li> <li>• NMEA 0183 Protocol Ver.4.10, BK GNSS Receiver Protocol</li> <li>• Supports batch data report mode</li> </ul>
Temperature Range	<ul style="list-style-type: none"> <li>• Normal operation: -40°C ~ +85°C</li> <li>• Storage temperature: -55°C ~ +125°C</li> <li>• Humidity: 5% ~ 95%</li> </ul>
Physical Characteristics	<ul style="list-style-type: none"> <li>• Size: 16±0.6 × 12.2±0.2 × 2.4±0.2mm</li> <li>• Weight: Approx. 0.9g (1 piece)</li> </ul>

## 1.2 Block Diagram

The EB1612RK-GGB is a high performance (BDS, GPS, GLONASS, Galileo, QZSS, IRNSS and SBAS) in all bands (L1,L5). satellite navigation receiver in a compact surface mount package. It is based on the BK1662 positioning technology, providing high performance signal acquisition and tracking. The simple UART serial interface and the standard NMEA-0183 protocol make usage of EB1612RK-GGB very easy and straightforward.

The EB1612RK-GGB module performs all the necessary system initialization, signal acquisition, signal tracking, data demodulation, and calculation of navigation solution autonomously.

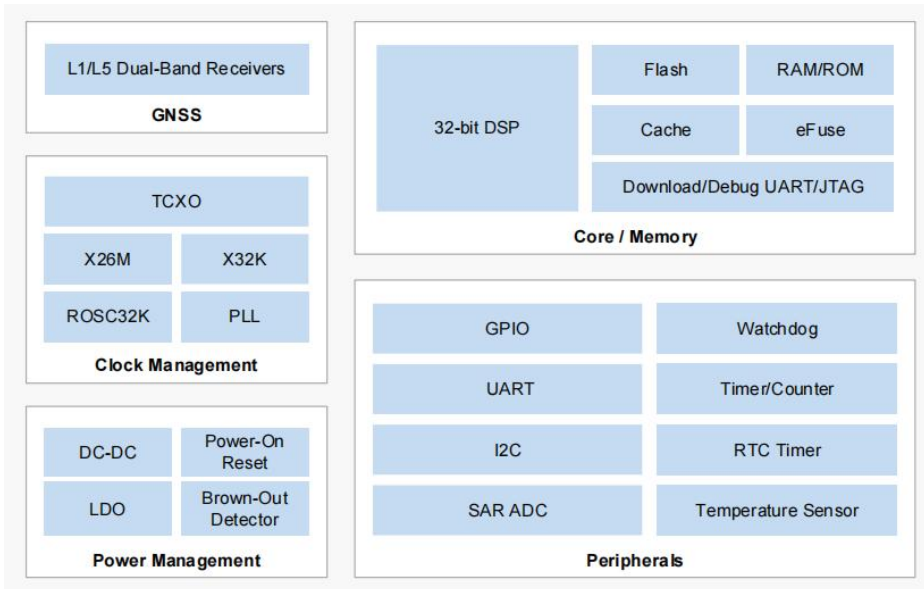
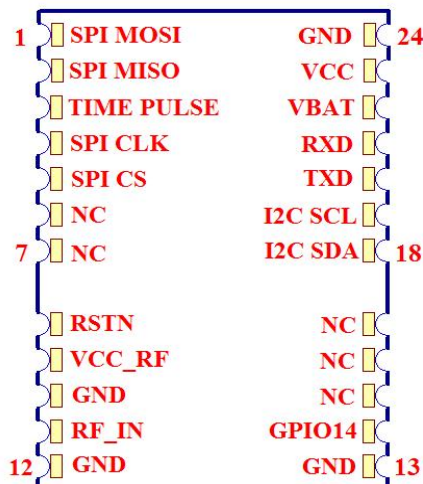

**Figure 2: Block Diagram**

## 2. Application

The module is equipped with a 24-pin SMT pad that connects to your application platform. Sub-interfaces included in the pad are described in details in the following chapters.

### 2.1. Pin Assignment



**Figure 3: Pin Assignment**

**Table 3: Pin Definition**

Pin No.	Name	Description
1	SPI MOSI	Serial port SPI MOSI port,leave it vacant when not in use
2	SPI MISO	Serial port SPI MISO port,leave it vacant when not in use
3	TIME PULSE	PPS OUT PUT
4	SPI CLK	Serial port SPI CLK port,leave it vacant when not in use
5	SPI CS	Serial port SPI CS port,leave it vacant when not in use
6.7.15.16.17	NC	No connect
8	RSTN	RESET leave it vacant when not in use
9	VCC_RF	Active antenna power supply
10	GND	Power GND
11	RF_IN	L1+L5 RF input
12	GND	Power GND
13	GND	Power GND
14	GPIO14	JTAG_TDO,leave it vacant when not in use
18	I2C SDA	Serial port I2C SDA port,leave it vacant when not in use
19	I2C SCL	Serial port I2C SCL port,leave it vacant when not in use
20	TXD	Serial port TXD port
21	RXD	Serial port RXD port
22	VBAT	Backup battery2.8V--3.3V,leave it vacant when not in use
23	VCC	Working voltage: 2.8-3.6V,Recommended use: 3.3V
24	GND	Power GND

## 2.2. Electrical Specification

**Table 4:Operating Conditions**

Parameter	Min	Typ	Max	Unit
Supply Voltage (VCC)	2.8	3.3	3.6	Volt
Acquisition Current (exclude active antenna current)		20		mA
Tracking Current (exclude active antenna current)		28		mA
<b>I/O port &amp;UART port working voltage :</b>				
Output Low Voltage	-		0.4	Volt
Output HIGH Voltage	2.4		-	Volt
Input LOW Voltage	0.3		0.7	Volt
Input HIGH Voltage	2.1		3.6	Volt
Input LOW Current	-10		10	uA
Input HIGH Current	-10		10	uA
RF Input Impedance (RFIN)		50		Ohm

**Table 5:Absolute Maximum Ratings**

Parameter	Minimum	Maximum	Condition
Supply Voltage (VCC)	-0.5	3.6	Volt
Input Pin Voltage	-0.5	VCC+0.5	Volt
Input Power at RF_IN		+20	dBm
Storage Temperature	-55	+100	degC

### 2.3. UART Interface

The module provides one universal asynchronous receiver& transmitter serial port. The module is designed as DCE (Data Communication Equipment), following the traditional DCE-DTE (Data Terminal Equipment) connection. The module and the client (DTE) are connected through the signals shown in the following figure. It supports data baud-rate : 9600,38400,115200,230400,460800,1000000,2000000.

#### UART port:

TXD: Send data to the RXD1 signal line of DTE.

RXD: Receive data from the TXD1 signal line of DTE.

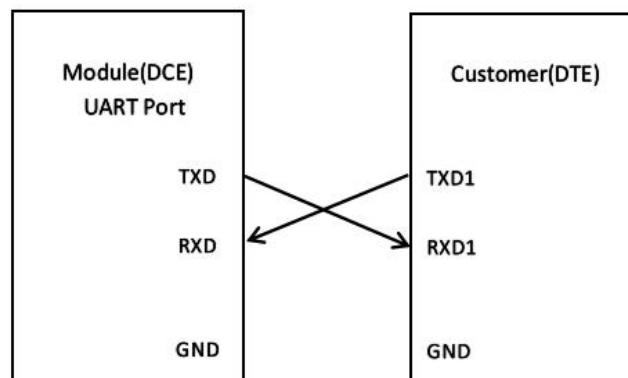
**Figure 4:Serial Port Connection**

#### This UART port has the following features:

- UART port can be used for NMEA Protocol output and proprietary commands input.
- The default output NMEA type setting is GGA,GSA,GSV,VTG,RMC,GLL.
- UART port supports the following data rates:  
9600,38400,115200,230400,460800,1000000,2000000bps.  
115200bps by default, 8 bits, no parity bit, 1 stop bit.
- Hardware flow control and synchronous operation are not supported.

The UART port does not support the RS-232 level but only CMOS level. If the module's UART port is connected to the UART port of a computer, it is necessary to add a level shift circuit between the module and the computer. Please refer to the following figure.

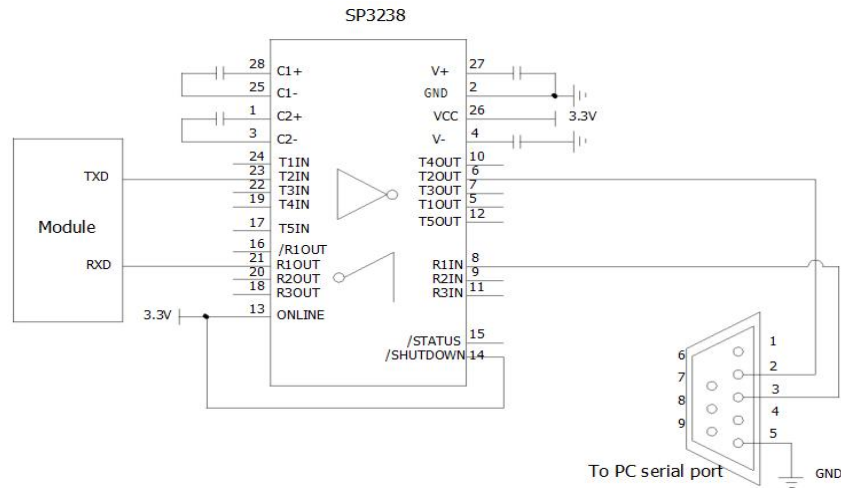
**Figure 5: RS-232 Level Shift Circuit**

### 3. Antenna Consideration

The EB1612RK-GGB is designed to use with active antenna, and passive antenna with higher antenna gain. Passive ceramic patch antenna is low-cost and provides good sensitivity. 50-ohm output larger size ceramic patch antenna with higher antenna gain can be connected directly to RF input of the module. Usually the ceramic patch antenna and EB1612RK-GGB are mounted on opposite side of the PCB to reduce possibility of picking up digital noise. To improve signal reception performance, use larger ground plane under the patch antenna if possible; larger the ground plane, larger the overall antenna gain. The center frequency of the ceramic patch antenna changes with ground plane size. For optimal L1+L5 operation, frequency bandwidth of the antenna needs to cover 1174MHz ~ 1179MHz and 1573MHz ~ 1606MHz respectively when mounted on the PCB. It is usual to ask the ceramic patch antenna vendor to select or tune a patch antenna that best matches the customer PCB.

Active antenna is essentially a passive antenna with built-in LNA and a coaxial cable to connect the antenna to the module. It has the flexibility of being located remotely from the module, but requires antenna power. Active antenna usually costs more than passive patch antenna, but the performance in low signal environments is usually better. Active antenna with gain of 10 ~ 20dB and noise figure less than 1.5dB can be used with EB1612RK-GGB .

Antenna Type	Passive	Active
GPS&QZSS Frequency (MHz)	1575.42 +/- 2 (L1) 1176.45 +/- 2 (L5)	1575.42 +/- 2 (L1) 1176.45 +/- 2 (L5)
BDS Frequency (MHz)	1561 .098+/- 2(B1I) 1575.42+/- 2(B1C) 1176.45+/- 2(B2A)	1561 .098+/- 2(B1I) 1575.42+/- 2(B1C) 1176.45+/- 2(B2A)
GLONASS Frequency (MHz)	1602MHz +/- 4(L1)	1602MHz +/- 4(L1)
GALILEO Frequency (MHz)	1575.42 +/- 2 (E1) 1176.45 +/- 12(E5)	1575.42 +/- 2(E1) 1176.45 +/- 12(E5)
IRNSS Frequency (MHz)	1176.45 +/- 12(L5)	1176.45 +/- 12(L5)
VSWR	< 2 (typical)	< 2 (typical)
Polarization	RHCP	RHCP
Antenna Gain	> 0dBi	> -2dBi
LNA Gain		20dB (typical)
Noise Figure		< 1.5dB
Total Gain		> 18dBi

## 4. Power Supply Requirement

EB1612RK-GGB requires a stable power supply, avoid ripple on VCC pin (<50mVpp). Power supply noise can affect the receiver's sensitivity. Bypass capacitors of 10uF and 0.1uF is recommended to be placed close to the module VCC pin; the values could be adjusted according to the amount and type of noise present on the supply line.

## 5. Backup Supply

The purpose of backup supply voltage pin (VBAT) is to keep the SRAM memory and the RTC powered when the module is powered down. This enables the module to have a faster time-to-first-fix when the module is powered on again. The backup current drain is less than 12μA. In normal powered on state, the internal processor access the SRAM and current drain is higher in active mode.

## 6. 1PPS Output

When using four or more satellites for 3D positioning, the rising edge of the pulse generating 1 pulse per second (Duration: 800 seconds) on 1PPS pins is aligned with the UTC seconds, and the accuracy is about 20nS. When it is not positioned, it outputs a constant low pulse.

## 7. Layout Guidelines

### Separate RF and digital circuits into different PCB regions.

It is necessary to maintain 50-ohm impedance throughout the entire RF signal path. Try keeping the RF signal path as short as possible.

Do not route the RF signal line near noisy sources such as digital signals, oscillators, switching power supplies, or other RF transmitting circuit. Do not route the RF signal under or over any other components (including EB1612RK-GGB), or other signal traces. Do not route the RF signal path on an inner layer of a multi-layer PCB to minimize signal loss. Avoid sharp bends for RF signal path. Make two 45-deg bends or a circular bend instead of a single 90-degree bend if needed.

Avoid vias with RF signal path whenever possible. Every via adds inductive impedance. Vias are acceptable for connecting the RF grounds between different layers. Each of the module's ground pins should have short trace tying immediately to the ground plane below through a via.

The bypass capacitors should be low ESR ceramic types and located directly adjacent to the pin they are for.

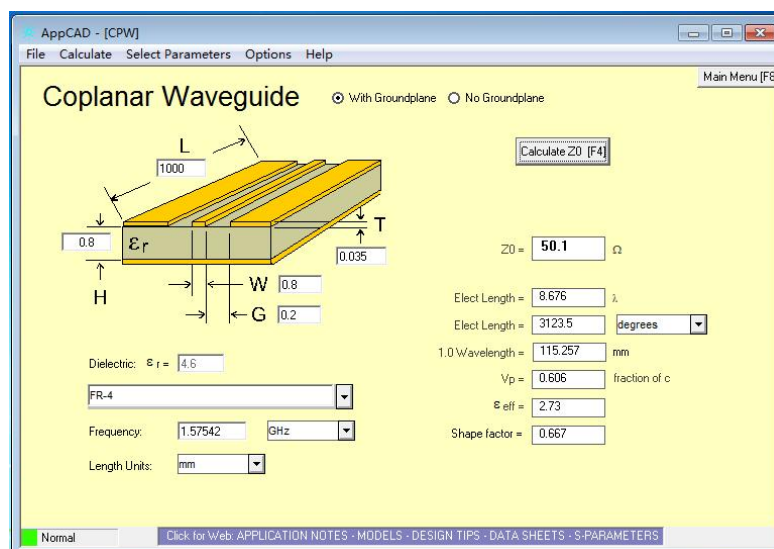

**Figure 6: Requires Of Antenna Design**

## 8. ESD handling precautions

EB1612RK-GGB series modules are Electrostatic Sensitive Devices (ESD). Observe precautions for handling! Failure to observe these precautions can result in severe damage to the GPS receiver!

GPS receivers are Electrostatic Sensitive Devices (ESD) and require special precautions when handling. Particular care must be exercised when handling patch antennas, due to the risk of electrostatic charges. In addition to standard ESD safety practices, the following measures should be taken into account whenever handling the receiver:

✧ Unless there is a galvanic coupling between the local GND(i.e. the work table) and the PCB GND, then the first point of contact when handling the PCB must always be between the local GND and PCB GND.



✧ Before mounting antenna patch, connect ground of the device. When handling the RF pin, do not come into contact with any charged capacitors and be careful when contacting materials that can develop charges (e.g. patch antenna ~10pF, coax cable ~50-80pF/m, soldering iron.....)



✧ To prevent electrostatic discharge through the RF input, do not touch any exposed antenna area. If there is any risk that such exposed antenna area is touched in non ESD protected work area, implement proper ESD protection measures in the design.



✧ When soldering RF connectors and patch antennas to the receiver's RF pin, make sure to use an ESD safe soldering iron (tip).



**Table 6: ESD Endurance Table (Temperature : 25°C, Humidity: 45%)**

Pin	Contact Discharge	Air Discharge
RF_IN	±5KV	±10KV
VCC	±5KV	±10KV
UART	±3KV	±6KV
Others	±2KV	±4KV



## 9. Mechanical Dimensions

9.1 This chapter describes the mechanical dimensions of the module.

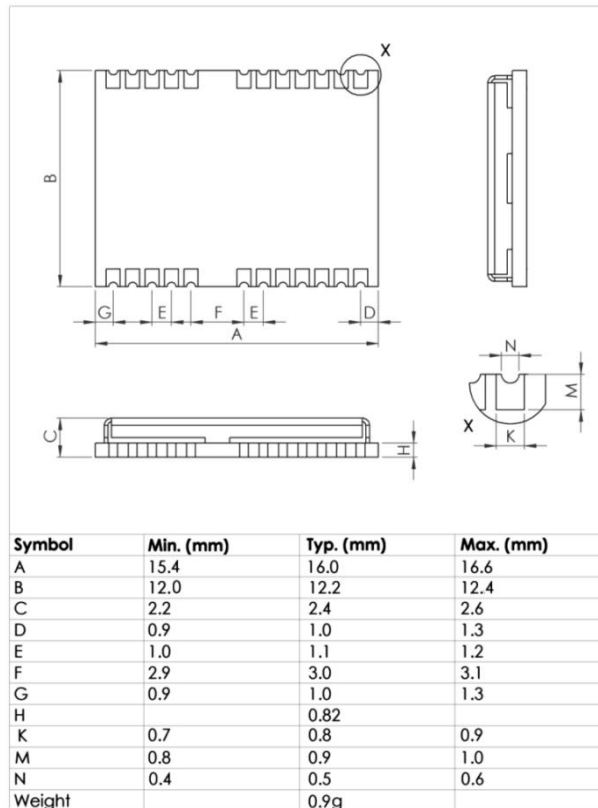

Figure 7: Mechanical Dimensions (Unit: mm)

9.2 Reference Charging Size for PCB (unit: mm)

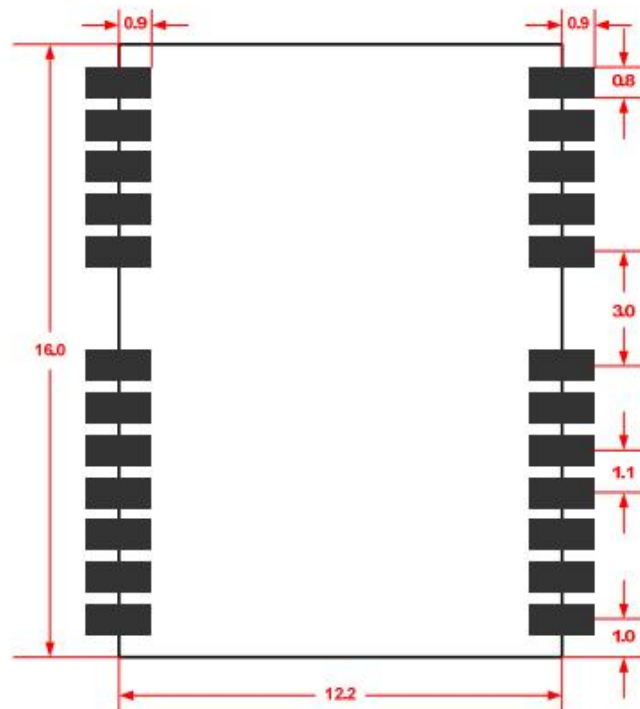
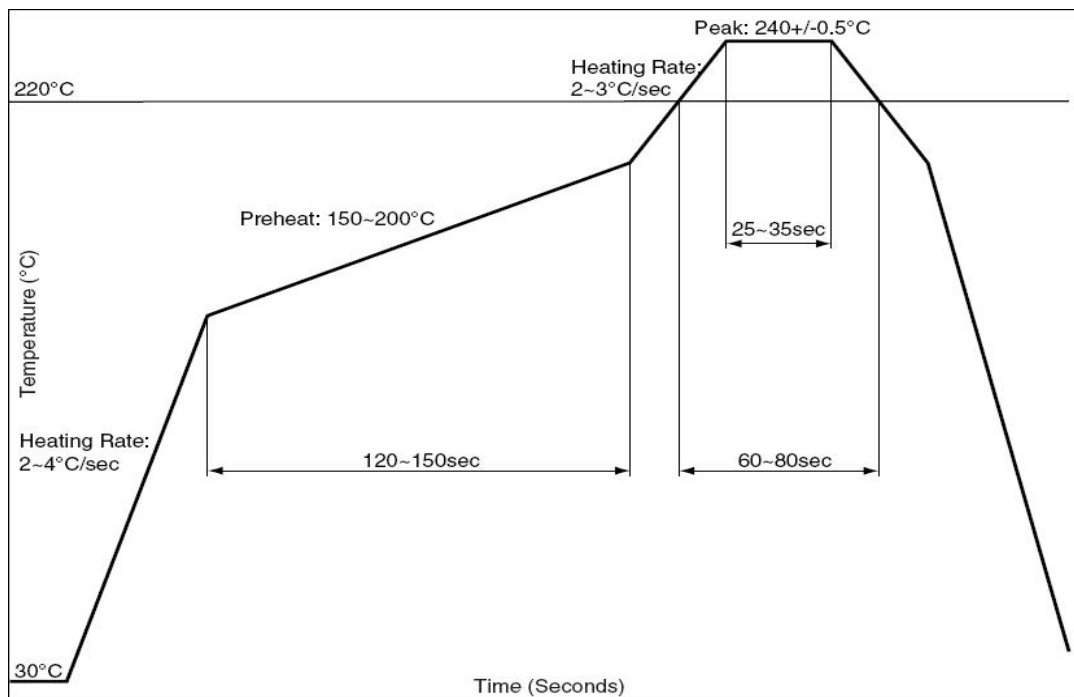

Figure 8: Reference Charging Size for PCB (unit: mm)

## 10. Manufacturing, Packaging Information

### 10.1. Assembly and Soldering

EB1612RK-GGB module is intended for SMT assembly and soldering in a Pb-free reflow process on the top side of the PCB. It is suggested that the minimum height of solder paste stencil is 100um to ensure sufficient solder volume. Pad openings of paste mask can be increased to ensure proper soldering and solder wetting over pads. It is suggested that the peak reflow temperature is 220~240°C (for SnAg3.0Cu0.5 alloy). The absolute maximum reflow temperature is 260°C. To avoid damage to the module when it is repeatedly heated, it is suggested that the module should be mounted after reflow soldering for the other side of PCB has been completed. Recommended reflow soldering thermal profile is shown below:



**Figure 9: Recommended Reflow Soldering Thermal Profile**

### 10.2. Moisture Sensitivity

EB1612RK-GGB module is sensitive to moisture. To prevent EB1612RK-GGB from permanent damage during reflow soldering, baking before reflow soldering is required in following cases:

- ✧ Humidity indicator card: One or more indicating spots are no longer blue.
- ✧ The seal is opened and the module is exposed to excessive humidity.

EB1612RK-GGB shall be baked for 192 hours in a cryogenic environment at 40°C+5°C/-0°C and <5%RH, or for 24 hours in a high-temperature environment at 125°C±5°C. As the plastic packaging tape is not heat-resistant, the module should be removed from the tape before baking, otherwise, the tape will be damaged due to high temperature heating, you can also refer to the actual production technology of the SMT factory.

**10.3. Tape and Reel Packaging**

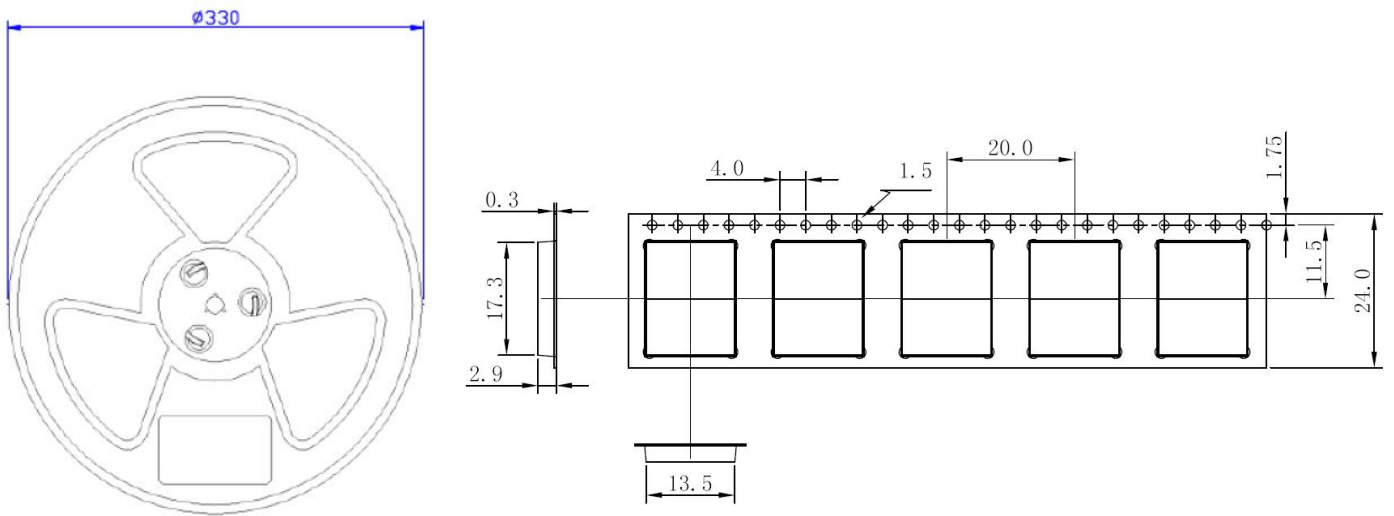

Unit: mm

Quantity per reel: 1000pcs

Length per reel: 20m

**Figure 10: Tape and Reel Specifications**



**Figure 11: Packaging physical Figure**

**Table 7: Reel Packaging**

Model Name	MOQ for MP	Minimum Package: 1000pcs
EB1612RK-GGB	1000pcs	Size: 365mm × 348mm ×50mm N.W: 0.9 kg G.W: 1.48 kg (±5%)

## 11. Supported GNSS augmentation systems

### 11.1 DGNSS – Differential GNSS

The RTK navigation mode needs to work in the data mode provided by RTCM version 3.3. The EB1612RK-GGB supports DGNSS function according to RTCM 10403.3 protocol. The decoded RTCM3.3 message is shown in the following table:

**Table 8**

No.	Data type	Message type	Description
1	RTCM 1074	MSM4	GPS pseudo-distance,Carrier phase,Carrier-noise ratio
2	RTCM 1077	MSM7	High precision GPS pseudo-distance,Carrier phase,Doppler,Carrier-noise ratio
3	RTCM 1084	MSM4	GLONASS pseudo-distance,carrier phase,carrier-noise ratio
4	RTCM 1087	MSM7	High precision GLONASS pseudo-distance,Carrier phase,Doppler,Carrier-noise ratio
5	RTCM 1094	MSM4	Galileo pseudo-distance,Carrier phase,Carrier-noise ratio
6	RTCM 1097	MSM7	High precision Galileo pseudo-distance,Carrier phase,Doppler,Carrier-noise ratio
7	RTCM 1104	MSM4	SBAS pseudo-distance,Carrier phase,Carrier-noise ratio
8	RTCM 1107	MSM7	High precision SBAS pseudo-distance,Carrier phase,Doppler,Carrier-noise ratio
9	RTCM 1114	MSM4	QZSS pseudo-distance,Carrier phase,Carrier-noise ratio
10	RTCM 1117	MSM7	High precision QZSS pseudo-distance,Carrier phase,Doppler,Carrier-noise ratio
11	RTCM 1124	MSM4	BEIDOU pseudo-distance,Carrier phase,Carrier-noise ratio
12	RTCM 1127	MSM7	High precision BEIDOU pseudo-distance,Carrier phase,Doppler,Carrier-noise ratio

## 12. NMEA 0183 Protocol

The output protocol supports NMEA-0183 standard. The implemented messages include GGA, GSA, GSV, VTG, RMC, GLL messages. The NMEA message output has the following sentence structure: \$AACCC , c-c\*hh.

**Table 9: The NMEA sentence structure**

Character	HEX	Description
“\$”	24	Start of sentence.
Aacc		Address field. “aa” is the talker identifier. “cc” identifies the sentence type.
“,”	2C	Field delimiter.
C-c		Data sentence block.
“*”	2A	Checksum delimiter.
Hh		Checksum field.
<CR><LF>	0D0A	Ending of sentence. (carriage return, line feed)

The formats of the supported NMEA messages are described as follows:

\$GNRMC,\$GNGLL,\$GNGGA,\$GPGSV,\$BDGSV,\$GLGSV,\$GAGSV,\$IRGSV,\$GNVTG,\$GNGSA.

**Table 10: Overview of NMEA messages**

<b>\$GNGGA</b>	Time, position, and fix related data of the receiver.
<b>\$GNGSA</b>	Used to represent the ID of satellites which are used for position fix. When GPS&GLONASS&Galileo & BDS satellites are used for positioning solutions, the ID of available positioning satellites is counted and output with multiple statements.
<b>\$GPGSV</b> <b>\$GLGSV</b> <b>\$GAGSV</b> <b>\$BDGSV</b> <b>\$IRGSV</b>	Satellite information about elevation, azimuth and CNR, satellites are used in position solution, a \$GPGSV sentence is used for GPS satellites, a \$GLGSV sentence is used for GLONASS satellites, a \$GAGSV sentence is used for GALILEO satellites. \$BDGSV sentence is used for BDS satellites. And \$IRGSV sentence is used for IRNSS satellites.
<b>\$GNVTG</b>	Course and speed relative to the ground
<b>\$GNRMC</b>	Time, date, position, course and speed data.
<b>\$GNGLL</b>	Position, time and fix status.

### 12.1 GGA – Global Positioning System Fix Data

Time, position and fix related data for a GNSS receiver.

Structure:\$GNGGA,hhmmss.sss,ddmm.mmmm,a,dddmm.mmmm,a,x,xx,x.x,x.x,M,x.x,M,x.x,xxxx\*hh

For example:\$GNGGA,175258.000,2447.0870,N,12100.5221,E,2,15,0.7,95.2,M,19.6,M,,0000\*72

Field	Name	Example	Description
1	UTC Time	175258.000	UTC of position in hhmmss.sss format, (000000.000 ~ 235959.999)
2	Latitude	2447.08700	Latitude in ddmm.mmmmm format Leading zeros transmitted
3	N/S Indicator	N	Latitude hemisphere indicator, ‘N’ = North, ‘S’ = South
4	Longitude	12100.52210	Longitude in dddmm.mmmmm format Leading zeros transmitted
5	E/W Indicator	E	Longitude hemisphere indicator, ‘E’ = East, ‘W’ = West

6	Quality Indicator	2	Quality Indicator 0: position fix unavailable 1: valid position fix, SPS mode 2: valid position fix, differential GPS mode 3: GPS PPS Mode, fix valid 4:RK fix 5:RK float fix 6: Estimated (dead reckoning) Mode
7	Satellites Used	15	Number of satellites in use, (00 ~ 56)
8	HDOP	0.7	Horizontal dilution of precision, (0.0 ~ 99.9)
9	Altitude	95.2	mean sea level (geoid), ( - 9999.9 ~ 17999.9)
10	Geoidal Separation	19.6	Geoidal separation in meters
11	Age pf Differential GPS data		Age of Differential GPS data NULL when DGPS not used
12	DGPS Station ID	0000	Differential reference station ID, 0000 ~ 1023
13	Checksum	72	

## 12.2 GSA – GNSS DOP and Active Satellites

GNSS receiver operating mode, satellites used in the navigation solution reported by the GGA sentence and DOP values.

Structure:\$GPGSA,A,x,xx,xx,xx,xx,xx,xx,xx,xx,xx,x.x,x.x,x.x,x\*hh

For example:\$GPGSA,A,3,21, 12,15,18,20,24,10,32,25,13,,,1.2,0.7,1.0,1\*18

Field	Name	Example	Description
1	Mode	A	Mode 'M' = Manual, forced to operate in 2D or 3D mode 'A' = Automatic, allowed to automatically switch 2D/3D
2	Mode	3	Fix type 1 = Fix not available 2 = 2D 3 = 3D
3	Satellite used 1~12	21, 12, 15, 18, 20, 24, 10, 32, 25, 13	01 ~ 32 are for GPS; 33 ~ 64 are for WAAS (PRN minus 87); 193 ~ 197 are for QZSS; 65 ~ 88 are for GLONASS (GL PRN) ; 01 ~ 36 are for GALILEO (GA PRN); 01 ~ 37 are for BDS (BD PRN). GPS, GLONASS, GALILEO and BDS satellites are differentiated by the GNSS system ID in table 8. Maximally 12 satellites are included in each GSA sentence
4	PDOP	1.2	Position dilution of precision (0.0 to 99.9)
5	HDOP	0.7	Horizontal dilution of precision (0.0 to 99.9)
6	VDOP	1.0	Vertical dilution of precision (0.0 to 99.9)
7	GNSS System ID	1	1 for GPS, 2 for GLONASS, 3 for GALILEO, 4 for BDS
8	Checksum	18	

### 12.3 GSV – GNSS Satellites in View

Number of satellites (SV) in view, satellite ID numbers, elevation, azimuth, and SNR value. Four satellites maximum per transmission.

Structure: \$GPGSV, x, x, xx, xx, xx, xx, xx, ..., xx, xx, xx, xx, xx, x\*hh

For example: \$GPGSV, 4,1, 13, 02,72, 109, 43,24, 69,035, 48,18, 52,330, 42,21, 49,246, 43, 1\*69

Field	Name	Example	Description
1	Number of message	4	Total number of GSV messages to be transmitted (1 - 5)
2	Sequence number	1	Sequence number of current GSV message
3	Satellites in view	13	Total number of satellites in view (00 ~ 20)
4	Satellite ID	02	01 ~ 32 are for GPS; 33 ~ 64 are for WAAS (PRN minus 87); 193 ~ 197 are for QZSS; 65 ~ 88 are for GLONASS (GL PRN) ; 01 ~ 36 are for GALILEO (GA PRN); 01 ~ 37 are for BDS (BD PRN). GPS, GLONASS, GALILEO and BDS satellites are differentiated by the GNSS system ID in table 8. Maximally 12 satellites are included in each GSV sentence
5	Elevation	72	Satellite elevation in degrees, (00 ~ 90)
6	Azimuth	109	Satellite azimuth angle in degrees, (000 ~ 359 )
7	SNR	43	C/No in dB (00 ~ 99) Null when not tracking
8	Signal ID	1	1 for L1/CA, 4 for L5/CA
9	Checksum	69	

### 12.4 RMC – Recommended Minimum Specific GNSS Data

Time, date, position, course and speed data provided by a GNSS navigation receiver.

Structure:\$GNRMC,hhmmss.sss,A,dddmm.mmmm,a,dddmm.mmmm,a,x.x,x.x,ddmmyy,,a\*hh

For example:\$GNRMC,175258.000,A,2447.0870,N,12100.5220,E,000.0,000.0,220617,,D\*75

Field	Name	Example	Description
1	UTC time	175258.000	UTC time in hhmmss.sss format (000000.00 ~ 235959.999)
2	Status	A	Status 'V' = Navigation receiver warning 'A' = Data Valid
3	Latitude	2447.08700	Latitude in dddmm.mmmmm format Leading zeros transmitted
4	N/S indicator	N	Latitude hemisphere indicator 'N' =North 'S' = South
5	Longitude	12100.52210	Longitude in dddmm.mmmmm format Leading zeros transmitted
6	E/W Indicator	E	Longitude hemisphere indicator 'E' = East 'W' = West
7	Speed over ground	000.0	Speed over ground in knots (000.0 ~ 999.9)
8	Course over ground	000.0	Course over ground in degrees (000.0 ~ 359.9)
9	UTC Date	220617	UTC date of position fix, ddmmyy format

10	Mode indicator	D	Mode indicator 'N' = Data not valid 'A' = Autonomous mode 'D' = Differential mode 'E' = Estimated (dead reckoning) mode
11	checksum	75	

## 12.5 VTG – Course Over Ground and Ground Speed

The actual course and speed relative to the ground.

Structure: GNV $TG,x.x,T,M,x.x,N,x.x,K,a*hh$

For example: \$GNVTG,000.0,T,M,000.0,N,000.0,K,D\*16

Field	Name	Example	Description
1	Course	000.0	True course over ground in degrees (000.0 ~ 359.9)
2	Speed	000.0	Speed over ground in knots (000.0 ~ 999.9)
3	Speed	000.0	Speed over ground in kilometers per hour (000.0 ~ 1800.0)
4	Mode	D	Mode indicator 'N' = Data not valid 'A' = Autonomous mode 'D' = Differential mode 'E' = Estimated (dead reckoning) mode
5	Checksum	16	

## 12.6 GLL – Latitude/Longitude

Latitude and longitude of current position, time, and status.

Structure: \$GNGLL,ddmm.mmmm,a,dddmm.mmmm,a,hmmss.sss,A,a\*hh

For example: \$GNGLL,2447.0870,N,12100.5221,E,175258.000,A,D\*42

Field	Name	Example	Description
1	Latitude	2447.08700	Latitude in ddmm.mmmmm format Leading zeros transmitted
2	N/S Indicator	N	Latitude hemisphere indicator 'N' = North 'S' = South
3	Longitude	12100.52210	Longitude in dddmm.mmmmm format Leading zeros transmitted
4	E/W Indicator	E	Longitude hemisphere indicator 'E' = East 'W' = West
5	UTC Time	175258.000	UTC time in hhmss.sss format (000000.000 ~ 235959.999)
6	Status	A	Status, 'A' = Data valid, 'V' = Data not valid
7	Mode Indicator	D	Mode indicator 'N' = Data not valid 'A' = Autonomous mode 'D' = Differential mode 'E' = Estimated (dead reckoning) mode
8	Checksum	42	