

General Description

The EB1010L5-BD is a receiving module that supports Single-Band&Multi-Mode. It has built-in highly integrated GNSS receiver chip, supports multi band and multi system cm4f (main frequency 350mhz, 22nm Technology) chip of Third-generation BeiDou Navigation Satellite System (BDS-3). Besides, it is capable of tracking all global civil navigation systems (BDS, GPS, GLONASS, Galileo, QZSS and SBAS) in all bands.

EB1010L5-BD module is based on the state of art BDS-3 architecture, integrating multi-band and multi-system GNSS RF and base band. This newly designed architecture makes this single chip achieve sub-meter level position accuracy without correction data from ground-based augmentation station and higher sensitivity, greater for improved jam resistance and multipath, provide a highly robust service in complicated environment.

EB1010L5-BD module contains BK1662 positioning engine inside, featuring high sensitivity, low power consumption, and fast TTFF. The superior cold start sensitivity allows it to acquire, track, and get position fix autonomously in difficult weak signal environment. The receiver's superior tracking sensitivity allows continuous position coverage in nearly all outdoor application environments. The high performance signal parameter search engine is capable of testing 16 million time-frequency hypotheses per second, offering superior signal acquisition and TTFF speed.

Applications

- LBS (Location Based Service)
- PND (Portable Navigation Device)
- Vehicle navigation system
- Mobile phone



Figure: EB1010L5-BD Top View

Features

- Build on high performance, low-power BK1662 chip set
- Ultra high Track sensitivity: - 163dBm
- Concurrent reception of Single-Band and multi- system satellite signals
- Supports all civil GNSS signals
- Supports BDS-3 signal
- Extremely fast TTFF at low signal level (Cold start $\leq 28s$, Hot start $\leq 1s$).
- Multipath detection and suppression
- Works with passive and active antenna
- Low power consumption: Max 25mA@3.3V
- NMEA-0183 compliant protocol or custom protocol
- Operating voltage: 2.8V to 3.6V
- SMD type with stamp holes
- Small form factor: $10.1 \pm 0.4 \times 9.7 \pm 0.2 \times 2.2 \pm 0.2$ mm
- Operating temperature $-40 \sim +125^{\circ}C$
- RoHS compliant (Lead-free)

1. Functional Description

1.1. Key Features

Table 1: Key Features

Parameter	Specification
GNSS engine	<ul style="list-style-type: none"> 200 tracking channels with fast search engine
GNSS reception	<ul style="list-style-type: none"> GPS/QZSS: L1 ,L5 BDS: B1I,B1C,B2A GLONASS: L1 Galileo: E1 E5 INRSS: L5 SBAS: WAAS, EGNOS, MSAS, GAGAN
Update rate	<ul style="list-style-type: none"> GNSS 1Hz
Position accuracy	<ul style="list-style-type: none"> GNSS < 1.5m CEP SBAS < 1.5m CEP
Velocity & Time accuracy	<ul style="list-style-type: none"> GNSS 0.01m/s CEP SBAS 0.05 m/s 1PPS 20 ns
Time to First Fix(TTFF)	<ul style="list-style-type: none"> Hot start 1.0 s Cold start 28 s AGPS 1.5s
Sensitivity	<ul style="list-style-type: none"> Cold start - 148dBm Hot start - 163dBm Reacquisition - 159dBm Tracking & navigation - 163dBm
GNSS Operating limit	<ul style="list-style-type: none"> Velocity 515m/s Altitude 18000m
Datum	<ul style="list-style-type: none"> Default WGS-84, User definable
UART Port	<ul style="list-style-type: none"> UART Port: TX and RX Supports baud rate from 9600bps to 961200bps, 115200bps by default. NMEA 0183 Protocol Ver. 4.00/4. 10, BK GNSS Receiver Protocol Supports batch data report mode
Temperature Range	<ul style="list-style-type: none"> Normal operation: -40°C ~ + 105°C Storage temperature: -55°C ~ + 100°C Humidity: 5% ~ 95%
Physical Characteristics	<ul style="list-style-type: none"> Size: 10. 1±0.4 × 9.7±0.2 × 2.2±0.2mm Weight: Approx. 0.4g

1.2. Block Diagram

The EB1010L5-BD is a high performance (BDS, GPS, GLONASS, Galileo, QZSS, IRNSS and SBAS) in all bands (L1,L5). satellite navigation receiver in a compact surface mount package. It is based on the BK1662 positioning technology, providing high performance signal acquisition and tracking. The simple UART serial interface and the standard NMEA-0183 protocol make usage of EB1010L5-BD very easy and straightforward.

The EB1010L5-BD module performs all the necessary system initialization, signal acquisition, signal tracking, data demodulation, and calculation of navigation solution autonomously.

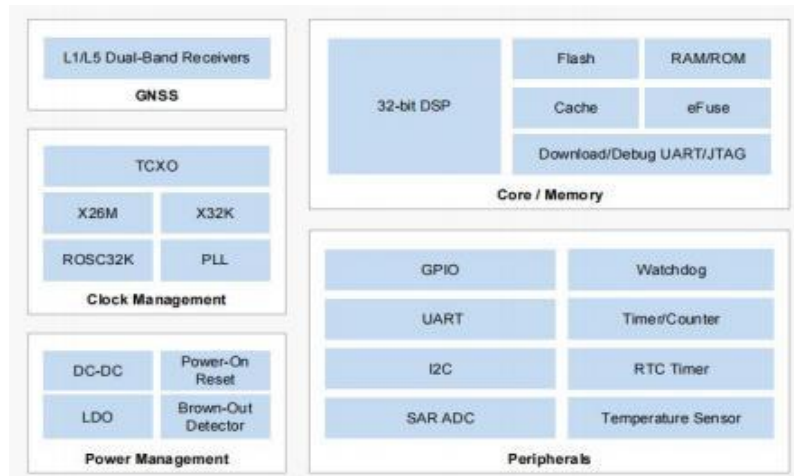

Figure 1: Block Diagram

2. Application

The module is equipped with a 18-pin SMT pad that connects to your application platform. Sub-interfaces included in the pad are described in details in the following chapters.

2.1. Pin Assignment



Figure 2: Pin Assignment

2.2. Pin Definition

Pin No	Name	Description
1	GND	Ground
2	TXD	MUX IO: GPIO, UART 0 Serial Data Transmit (UOUT0)
3	RXD	MUX IO: GPIO, UART 0 Serial Data Receive (UIN0)
4	PPS	One-pulse-per-second (1PPS) time mark output, 3.3V LVTTTL. The rising edge synchronized to UTC second when getting 3D position fix. The pulse duration is about 800usec at rate of 1 Hz
5	EXTINT	External Interrupt Pin
6	VBCAKUP	Buckup Power input Pin
8	VCC	Main power supply, 3.3V +/- 10%
9	RESET_N	Leave it Open if not used
10	GND	Ground
11	RF_IN	RF signal input
12	GND	Ground
14	VCC_RF	RF section output voltage. It's can be used to supply powers to an external active antenna.
16	SDA	I2C SDA Pin
17	SCL	I2C SCL Pin
18	Reserved	
7. 13. 15	Reserved	

2.3. Electrical Specification

Operating Conditions

Parameter	Min	Typ	Max	Unit
Supply Voltage (VCC)	2.8	3.3	3.6	Volt
Acquisition Current (exclude active antenna current)		25		mA
Tracking Current (exclude active antenna current)		20		mA
I/O port & UART port working voltage :				
Output Low Voltage	-		0.4	Volt
Output HIGH Voltage	2.4		-	Volt
Input LOW Voltage	0.3		0.7	Volt
Input HIGH Voltage	2.1		3.6	Volt
Input LOW Current	-10		10	uA
Input HIGH Current	-10		10	uA
RF Input Impedance (RFIN)		50		Ohm

Absolute Maximum Ratings

Parameter	Minimum	Maximum	Condition
Supply Voltage (VCC)	-0.5	3.6	Volt
Input Pin Voltage	-0.5	VCC+0.5	Volt
Input Power at RF_IN		+20	dBm
Storage Temperature	-55	+100	degC

2.4. UART Interface

The module provides one universal asynchronous receiver& transmitter serial port. The module is designed as DCE (Data Communication Equipment), following the traditional DCE- DTE (Data Terminal Equipment) connection. The module and the client (DTE) are connected through the signals shown in the following figure. It supports data baud-rate from 9600bps to 961200bps.

UART port:

TXD: Send data to the RXD1 signal line of DTE.

RXD: Receive data from the TXD1 signal line of DTE.

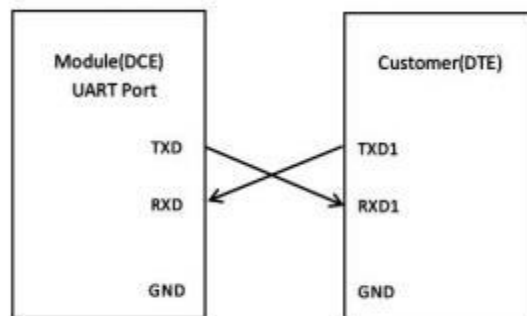

Figure 3: Serial Port Connection

This UART port has the following features:

- UART port can be used for NMEA Protocol output and proprietary commands input.
- The default output NMEA type setting is GGA, GSA, GSV, RMC
- UART port supports the following data rates:
9600, 14400, 19200, 38400, 57600, 115200, 961200bps.
115200bps by default, 8 bits, no parity bit, 1 stop bit.
- Hardware flow control and synchronous operation are not supported.

The UART port does not support the RS-232 level but only CMOS level. If the module's UART port is connected to the UART port of a computer, it is necessary to add a level shift circuit between the module and the computer. Please refer to the following figure.

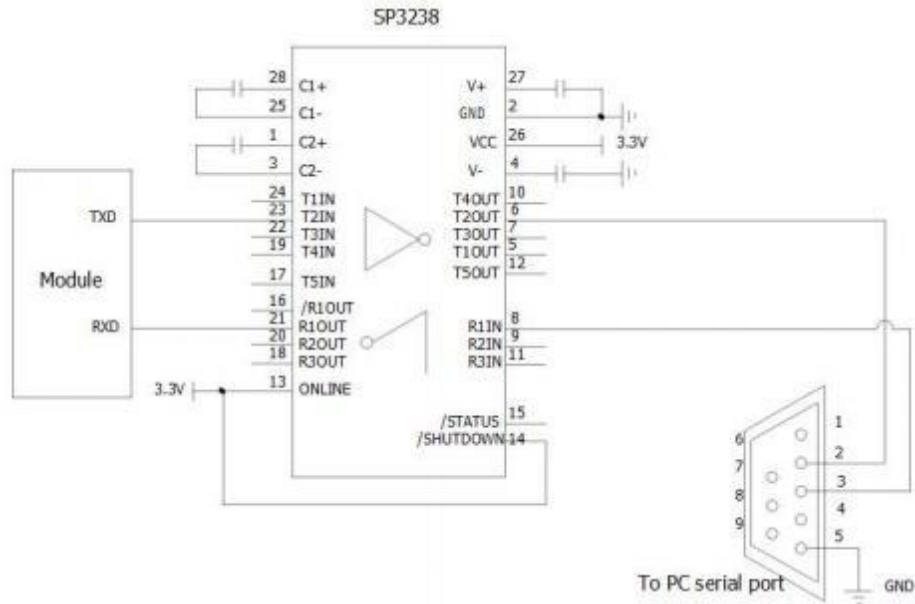

Figure 5: RS-232 Level Shift Circuit

3. Antenna Consideration

The EB1010L5-BD is designed to use with active antenna, and passive antenna with higher antenna gain.

Passive ceramic patch antenna is low-cost and provides good sensitivity. 50-ohm output larger size ceramic patch antenna with higher antenna gain can be connected directly to RF input of the module. Usually the ceramic patch antenna and EB1010L5-BD are mounted on opposite side of the PCB to reduce possibility of picking up digital noise. To improve signal reception performance, use larger ground plane under the patch antenna if possible; larger the ground plane, larger the overall antenna gain. The center frequency of the ceramic patch antenna changes with ground plane size. For optimal L1 peration, frequency bandwidth of the antenna needs to cover 1174MHz ~ 1179MHz and 1573MHz ~ 1606MHz respectively when mounted on the PCB. It is usual to ask the ceramic patch antenna vendor to select or tune a patch antenna that best matches the customer PCB.

Active antenna is essentially a passive antenna with built-in LNA and a coaxial cable to connect the antenna to the module. It has the flexibility of being located remotely from the module, but requires antenna power. Active antenna usually costs more than passive patch antenna, but the performance in low signal environments is usually better. Active antenna with gain of 10 ~ 20dB and noise figure less than 1.5dB can be used with EB1010L5-BD.

Antenna Type	Passive	Active
GPS&QZSS Frequency (MHz)	1575.42 +/- 2 (L1) 1176.45+/- 12 (L5)	1575.42 +/- 2 (L1) 1176.45+/- 12 (L5)
BDS Frequency (MHz)	1561 .098+/- 2(B1) 1575.42 +/- 2 (B1C) 1176.45+/- 2 (B2A5)	1561 .098+/- 2(B1I) 1575.42 +/- 2 (B2C) 1176.45+/- 2 (B2A)
GLONASS Frequency (MHz)	1602MHz +/- 4(L1)	1602MHz +/- 4(L1)
GALILEO Frequency (MHz)	1575.42+/- 2 (E2) 1176.45+/- 12 (E5)	1575.42+/- 2 (E1) 1176.45+/- 12 (E5)
IRNSS Frequency (MHz)	1176.45+/- 12 (L5)	1176.45+/- 12 (L5)
VSWR	< 2 (typical)	< 2 (typical)
Polarization	RHCP	RHCP
Antenna Gain	> 0dBi	> -2dBi
LNA Gain		20dB (typical)
Noise Figure		< 1.5dB
Total Gain		> 18dBi

4. Power Supply Requirement

EB1010L5-BD requires a stable power supply, avoid ripple on VCC pin (<50mVpp). Power supply noise can affect the receiver's sensitivity. Bypass capacitors of 10 uF and 0.1 uF is recommended to be placed close to the module VCC pin; the values could be adjusted according to the amount and type of noise present on the supply line.

5. Backup Supply

The purpose of backup supply voltage pin (VBAT) is to keep the SRAM memory and the RTC powered when the module is powered down. This enables the module to have a faster time-to-first-fix when the module is powered on again. The backup current drain is less than 12µA. In normal powered on state, the internal processor access the SRAM and current drain is higher in active mode.

6.1PPS Output

- When using four or more satellites for 3D positioning , the rising edge of the pulse generating 1 pulse per second (Duration: 800 seconds) on 1PPS pins is aligned with the UTC seconds, and the accuracy is about 20nS. When it is not positioned, it outputs a constant low pulse.

7. Layout Guidelines

Separate RF and digital circuits into different PCB regions.

It is necessary to maintain 50-ohm impedance throughout the entire RF signal path. Try keeping the RF signal path as short as possible.

Do not route the RF signal line near noisy sources such as digital signals, oscillators, switching power supplies, or other RF transmitting circuit. Do not route the RF signal under or over any other components (including EB1010L5-BD), or other signal traces. Do not route the RF signal path on an inner layer of a multi-layer PCB to minimize signal loss. Avoid sharp bends for RF signal path. Make two 45-deg bends or a circular bend instead of a single 90-degree bend if needed.

Avoid vias with RF signal path whenever possible. Every via adds inductive impedance. Vias are acceptable for connecting the RF grounds between different layers. Each of the module's ground pins should have short trace tying immediately to the ground plane below through a via.

The bypass capacitors should be low ESR ceramic types and located directly adjacent to the pin they are for.

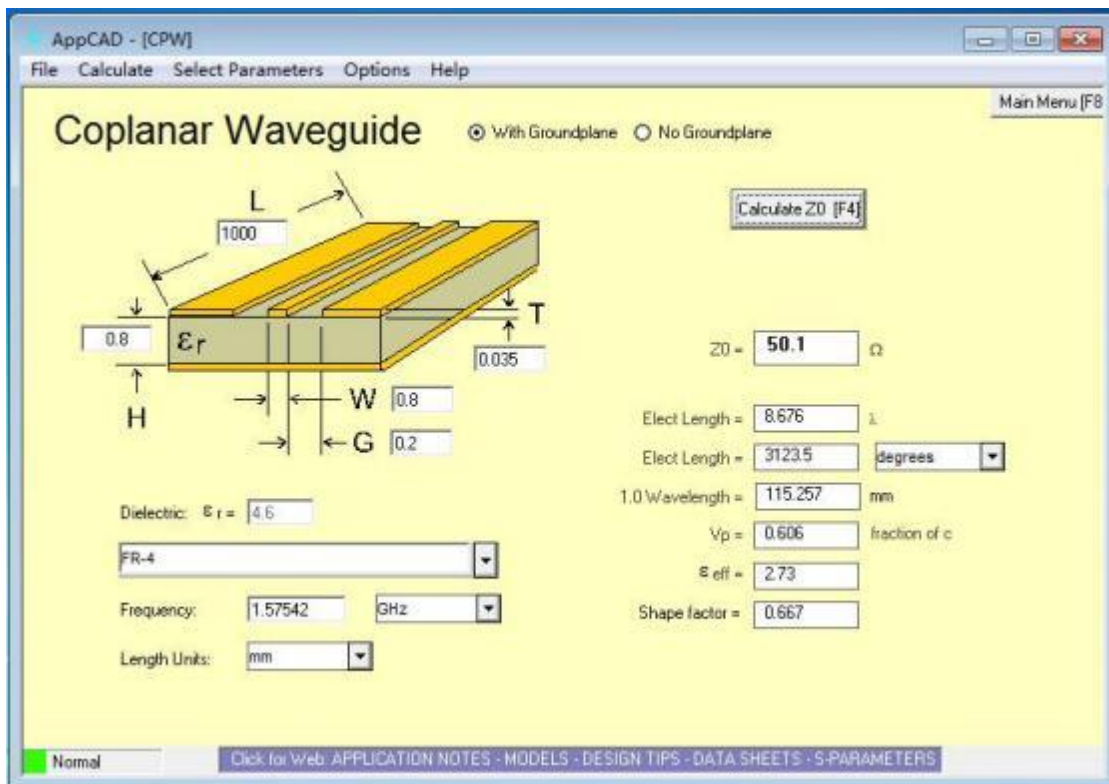

Requires Of Antenna Design

8.ESD handling precautions

EB1010L5-BD series modules are Electrostatic Sensitive Devices (ESD). Observe precautions for handling! Failure to observe these precautions can result in severe damage to the GPS receiver!

GPS receivers are Electrostatic Sensitive Devices (ESD) and require special precautions when handling. Particular care must be exercised when handling patch antennas, due to the risk of electrostatic charges. In addition to standard ESD safety practices, the following measures should be taken into account whenever handling the receiver:

- ❖ Unless there is a galvanic coupling between the local GND(i.e. the work table) and the PCB GND, then the first point of contact when handling the PCB must always be between the local GND and PCB GND.
- ❖ Before mounting antenna patch, connect ground of the device
When handling the RF pin, do not come into contact with any charged capacitors and be careful when contacting materials that can develop charges (e.g. patch antenna ~10pF, coax cable ~50-80pF/m, soldering iron.. ...)
- ❖ To prevent electrostatic discharge through the RF input, do not touch any exposed antenna area. If there is any risk that such exposed antenna area is touched in non ESD protected work area, implement proper ESD protection measures in the design.
- ❖ When soldering RF connectors and patch antennas to the receiver’s RF pin, make sure to use an ESD safe soldering iron (tip).



Table 1: ESD Endurance Table (Temperature : 25°C, Humidity: 45%)

Pin	Contact Discharge	Air Discharge
RF_IN	±5KV	± 10KV
VCC	±5KV	± 10KV
UART	±3KV	±6KV
Others	±2KV	±4KV

9. Mechanical Dimensions

This chapter describes the mechanical dimensions of the module.

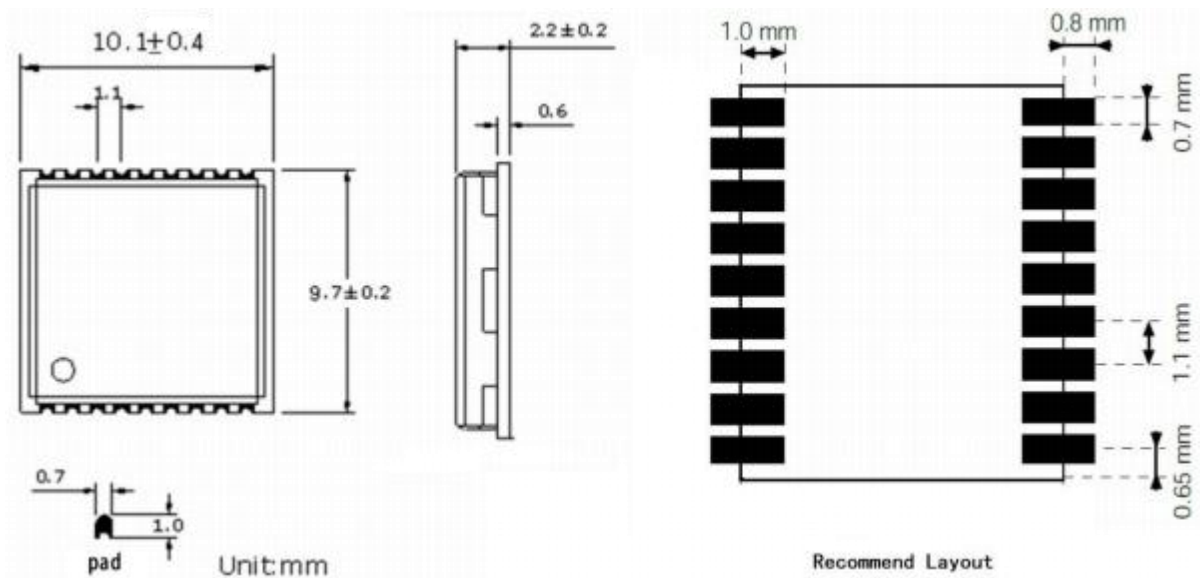
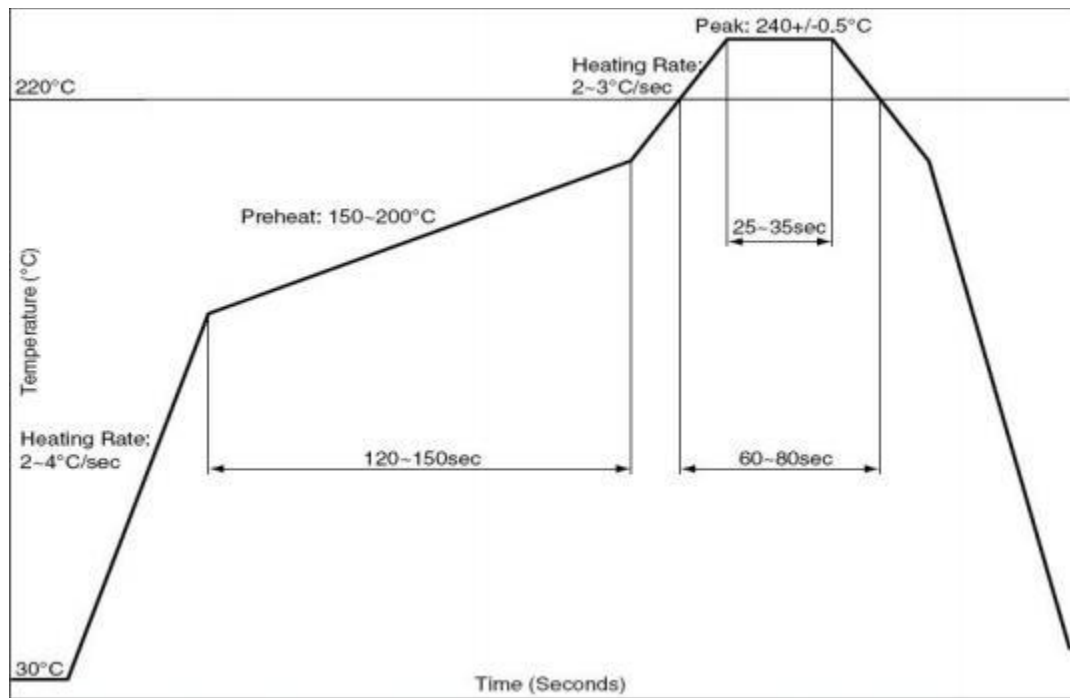

Figure 6: Top view Dimensions

10 .Manufacturing, Packaging and Ordering Information

10.1. Assembly and Soldering

EB1010L5-BD module is intended for SMT assembly and soldering in a Pb-free reflow process on the top side of the PCB. It is suggested that the minimum height of solder paste stencil is 100 um to ensure sufficient solder volume. Pad openings of paste mask can be increased to ensure proper soldering and solder wetting over pads. It is suggested that the peak reflow temperature is 220~240°C (for SnAg3.0Cu0.5 alloy). The absolute maximum reflow temperature is 260°C. To avoid damage to the module when it is repeatedly heated, it is suggested that the module should be mounted after reflow soldering for the other side of PCB has been completed. Recommended reflow soldering thermal profile is shown below:



10.2. Moisture Sensitivity

EB1010L5-BD module is sensitive to moisture. To prevent EB1010L5-BD from permanent damage during reflow soldering, baking before reflow soldering is required in following cases:

- ❖ Humidity indicator card: One or more indicating spots are no longer blue.
- ❖ The seal is opened and the module is exposed to excessive humidity.

EB1010L5-BD shall be baked for 192 hours in a cryogenic environment at 40°C+5°C/-0°C and <5%RH, or for 24 hours in a high-temperature environment at 125°C±5°C. As the plastic packaging tape is not heat-resistant, the module should be removed from the tape before baking, otherwise, the tape will be damaged due to high temperature heating, you can also refer to the actual production technology of the SMT factory.

10.3. Tape and Reel Packaging

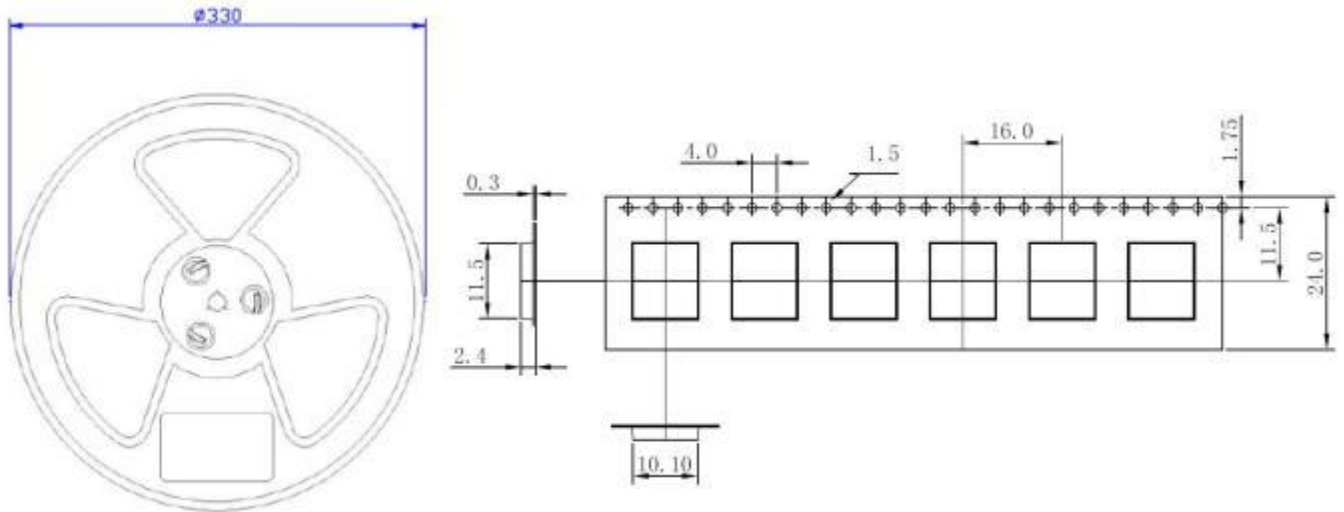

Unit: mm

Quantity per reel:1000pcs

Lengh per reel: 16m

Figure 8: Tape and Reel Specifications



Figure 9: Packaging physical Figure

Table 2: Reel Packaging

Model Name	MOQ for MP	Minimum Package: 1000pcs
EB1010L5-BD	1000pcs	Size: 365mm × 348mm × 50mm N.W: 0.4 kg G.W: 0.98 kg

11. NMEA 0183 Protocol

The output protocol supports NMEA- 0 1 8 3 standard. The implemented messages include GGA, GSA, GSV, RMC messages. The NMEA message output has the following sentence structure: \$ AACCC , c- c* hh.

The formats of the supported NMEA messages are described as follows:

GNRMC.GNGGA.GPGSA.BDGSA.GLGSA.GAGSA.IRGSA.GPGSV.BDGSV.GLGSV.GAGSV.IRGSV

11.1 GGA – Global Positioning System Fix Data

Time, position and fix related data for a GNSS receiver.

Structure: \$ GNGGA, hhhmss.sss, ddmm.mmmmm, a, dddmm.mmmmm, a, x, xx, x. x, x. x, M, x. x, M, x. x, xxxx*hh

For example:\$GNGGA, 175258.000,2447.0870,N, 12100.5221,E,2, 15,0.7,95.2,M, 19.6,M,,0000*72

Field	Name	Example	Description
1	UTC Time	175258.000	UTC of position in hhhmss.sss format, (000000.000 ~ 235959.999)
2	Latitude	2447.08700	Latitude in ddmm.mmmmm format Leading zeros transmitted
3	N/S Indicator	N	Latitude hemisphere indicator, 'N' = North, 'S' = South
4	Longitude	12100.52210	Longitude in dddmm.mmmmm format Leading zeros transmitted
5	E/W Indicator	E	Longitude hemisphere indicator, 'E' = East, 'W' = West
6	Quality Indicator	2	Quality Indicator 0: position fix unavailable 1: valid position fix, SPS mode 2: valid position fix, differential GPS mode 3: GPS PPS Mode, fix valid 6: Estimated (dead reckoning) Mode
7	Satellites Used	15	Number of satellites in use, (00 ~ 56)
8	HDOP	0.7	Horizontal dilution of precision, (0.0 ~ 99.9)
9	Altitude	95.2	mean sea level (geoid), (- 9999.9 ~ 17999.9)
10	Geoidal Separation	19.6	Geoidal separation in meters
11	Age pf Differential GPS data		Age of Differential GPS data NULL when DGPS not used
12	DGPS Station ID	0000	Differential reference station ID, 0000 ~ 1023
13	Checksum	72	

11.2 GSA – GNSS DOP and Active Satellites

GNSS receiver operating mode, satellites used in the navigation solution reported by the GGA sentence and DOP values.

Structure: \$GPGSA, A, x, xx, xx, xx, xx, xx, xx, xx, xx, xx, xx, xx, x, x, x, x, x, x*hh

For example:\$GPGSA,A,3,21, 12, 15, 18,20,24, 10,32,25, 13,, 1.2,0.7, 1.0, 1*18

Field	Name	Example	Description
1	Mode	A	Mode 'M' = Manual, forced to operate in 2D or 3D mode 'A' = Automatic, allowed to automatically switch 2D/3D
2	Mode	3	Fix type 1 = Fix not available 2 = 2D 3 = 3D
3	Satellite used 1~ 12	21, 12, 15, 18, 20, 24, 10, 32, 25, 13	01 ~ 32 are for GPS; 33 ~ 64 are for WAAS (PRN minus 87); 193 ~ 197 are for QZSS; 65 ~ 88 are for GLONASS (GL PRN) ; 01 ~ 36 are for GALILEO (GA PRN); 01 ~ 37 are for BDS (BD PRN). GPS, GLONASS, GALILEO and BDS satellites are differentiated by the GNSS system ID in table 3. Maximally 12 satellites are included in each GSA sentence
4	PDOP	1.2	Position dilution of precision (0.0 to 99.9)
5	HDOP	0.7	Horizontal dilution of precision (0.0 to 99.9)
6	VDOP	1.0	Vertical dilution of precision (0.0 to 99.9)
7	GNSS System ID	1	1 for GPS, 2 for GLONASS, 3 for GALILEO, 4 for BDS
8	Checksum	18	

11.3 GSV – GNSS Satellites in View

Number of satellites (SV) in view, satellite ID numbers, elevation, azimuth, and SNR value. Four satellites maximum per transmission.

Structure: \$GPGSV , x , x , xx , xx , xx , xx , xx , ... , xx , xx , xx , xx , xx , x*hh

For example : \$GPGSV , 4, 1 , 13 , 02,72 , 109 , 43,24 , 69,035 , 48, 18 , 52,330 , 42,21 , 49,246 , 43 , 1*69

Field	Name	Example	Description
1	Number of message	4	Total number of GSV messages to be transmitted (1 - 5)
2	Sequence number	1	Sequence number of current GSV message
3	Satellites in view	13	Total number of satellites in view (00 ~ 20)
4	Satellite ID	02	01 ~ 32 are for GPS; 33 ~ 64 are for WAAS (PRN minus 87); 193 ~ 197 are for QZSS; 65 ~ 88 are for GLONASS (GL PRN) ; 01 ~ 36 are for GALILEO (GA PRN); 01 ~ 37 are for BDS (BD PRN). GPS, GLONASS, GALILEO and BDS satellites are differentiated by the GNSS system ID in table 3. Maximally 12 satellites are included in each GSA sentence
5	Elevation	72	Satellite elevation in degrees, (00 ~ 90)

6	Azimuth	109	Satellite azimuth angle in degrees, (000 ~ 359)
7	SNR	43	C/No in dB (00 ~ 99) Null when not tracking
8	Signal ID	1	1 for L1/CA, 4 for L5/CA
9	Checksum	69	

11.4 RMC – Recommended Minimum Specific GNSS Data

Time, date, position, course and speed data provided by a GNSS navigation receiver.

Structure: \$ GNRMC, hhmmss.sss, A, dddmm. mmmm, a, dddmm. mmmm, a, x. x, x. x, ddmmy, , , a* h

h For

example:\$GNRMC,175258.000,A,2447.0870,N,12100.5220,E,000.0,000.0,220617,,,D*75

Field	Name	Example	Description
1	UTC time	175258.000	UTC time in hhmmss.sss format (000000.00 ~ 235959.999)
2	Status	A	Status 'V' = Navigation receiver warning 'A' = Data Valid
3	Latitude	2447.08700	Latitude in dddmm.mmmmm format Leading zeros transmitted
4	N/S indicator	N	Latitude hemisphere indicator 'N' =North 'S' = South
5	Longitude	12100.52210	Longitude in dddmm.mmmmm format Leading zeros transmitted
6	E/W Indicator	E	Longitude hemisphere indicator 'E' = East 'W' = West
7	Speed over ground	000.0	Speed over ground in knots (000.0 ~ 999.9)
8	Course over ground	000.0	Course over ground in degrees (000.0 ~ 359.9)
9	UTC Date	220617	UTC date of position fix, ddmmyy format
10	Mode indicator	D	Mode indicator 'N' = Data not valid 'A' = Autonomous mode 'D' = Differential mode 'E' = Estimated (dead reckoning) mode
11	checksum	75	