

## General Description

Delin Comm EM1612-G is a receiving module that supports single frequency and multi-mode. It has built-in highly integrated GNSS receiver chip, supports multi band and multi system cm4f (main frequency 428 MHz, 22nm Technology) chip of Third-generation BeiDou Navigation Satellite System (BDS-3). Besides, it is capable of tracking all global civil navigation systems (BDS, GPS, GLONASS, Galileo, QZSS and SBAS) in all bands.

EM1612-G module is based on the state of art CYNOSURE III architecture, integrating single-band and multi-system GNSS RF and baseband. This newly designed architecture makes this single chip achieve sub-meter level position accuracy without correction data from ground-based augmentation station and higher sensitivity, greater for improved jam resistance and multipath, provide a highly robust service in complicated environment.

EM1612-G module contains AG3352Q positioning engine inside, featuring high sensitivity, low power consumption, and fast TTFF. The superior cold start sensitivity allows it to acquire, track, and get position fix autonomously in difficult weak signal environment. The receiver's superior tracking sensitivity allows continuous position coverage in nearly all outdoor application environments. The high performance signal parameter search engine is capable of testing 16 million time-frequency hypotheses per second, offering superior signal acquisition and TTFF speed.

## Applications

- LBS (Location Based Service)
- PND (Portable Navigation Device)
- Vehicle navigation system
- Mobile phone



**Figure: EM1612-G Top View**

## Features

- Build on high performance, low-power MediaTek AG3352Q chip set
- Ultra high track sensitivity: - 165dBm
- Concurrent reception of single-band and multi-system satellite signals
- Supports all civil GNSS signals
- Supports BDS-3 signal
- Extremely fast TTFF at low signal level (Cold start  $\leq 24s$ , Hot start  $\leq 1s$ ).
- Multipath detection and suppression
- Works with passive and active antenna
- Low power consumption: 12 mA@3.3V
- NMEA-0183 compliant protocol or custom protocol
- Operating voltage: 2.8V to 3.6V
- SMD type with stamp holes
- Small form factor: 16x12x2.6mm
- Operating temperature -40 ~ +85°C
- RoHS compliant (Lead-free)

# 1. Functional Description

## 1.1. Key Features

**Table 1: Key Features**

Parameter	Specification
GNSS engine	<ul style="list-style-type: none"> <li>GNSS engine has 47SVs channels and DSP accelerators</li> </ul>
GNSS reception	<ul style="list-style-type: none"> <li>GPS/QZSS: L1 C/A, L1C</li> <li>BDS: B1I</li> <li>GLONASS: L1</li> <li>Galileo: E1</li> <li>SBAS: WAAS, EGNOS, MSAS, GAGAN</li> </ul>
Update rate	<ul style="list-style-type: none"> <li>GNSS 10Hz Maximum</li> </ul>
Position accuracy <sup>[1]</sup>	<ul style="list-style-type: none"> <li>GNSS &lt; 1m CEP</li> <li>SBAS &lt; 1m CEP</li> <li>D-GNSS &lt;50cm CEP</li> </ul>
Velocity & Time accuracy	<ul style="list-style-type: none"> <li>GNSS 0.01m/s CEP</li> <li>SBAS 0.05 m/s</li> <li>D-GNSS 0.05 m/s</li> <li>1PPS 25 ns</li> </ul>
Time to First Fix(TTFF) <sup>[1]</sup>	<ul style="list-style-type: none"> <li>Hot start 1 sec</li> <li>Cold start 24 secs</li> </ul>
Sensitivity <sup>[1]</sup>	<ul style="list-style-type: none"> <li>Cold start - 148dBm</li> <li>Hot start - 155dBm</li> <li>Reacquisition - 158dBm</li> <li>Tracking &amp; navigation - 165dBm</li> </ul>
GNSS Operating limit	<ul style="list-style-type: none"> <li>Velocity 515m/s</li> <li>Altitude 18,000m</li> </ul>
Datum	<ul style="list-style-type: none"> <li>Default WGS-84, User definable</li> </ul>
UART Port	<ul style="list-style-type: none"> <li>UART Port: TXD and RXD</li> <li>Supports baud rate from 9600 bps to 961200 bps.</li> <li>NMEA 0183 Protocol Ver. 4.00/4.10, Cynosure GNSS Receiver Protocol</li> </ul>
Temperature Range	<ul style="list-style-type: none"> <li>Normal operation: -40°C ~ +85°C</li> <li>Storage temperature: -55°C ~ + 100°C</li> <li>Humidity: 5% ~ 95%</li> </ul>
Physical Characteristics	<ul style="list-style-type: none"> <li>Size: 16±0.15×12.2±0.15×2.6±0.1mm</li> <li>Weight: Approx. 1.0g</li> </ul>

### 1.2. Block Diagram

The EM1612-G is a high performance (BDS, GPS, GLONASS, Galileo, QZSS and SBAS) in all bands . satellite navigation receiver in a compact surface mount package. It is based on the AG3352Q positioning technology, providing high performance signal acquisition and tracking. The simple UART serial interface and the standard NMEA-0183 protocol make usage of EM1612-G very easy and straightforward.

The EM1612-G module performs all the necessary system initialization, signal acquisition, signal tracking, data demodulation, and calculation of navigation solution autonomously.

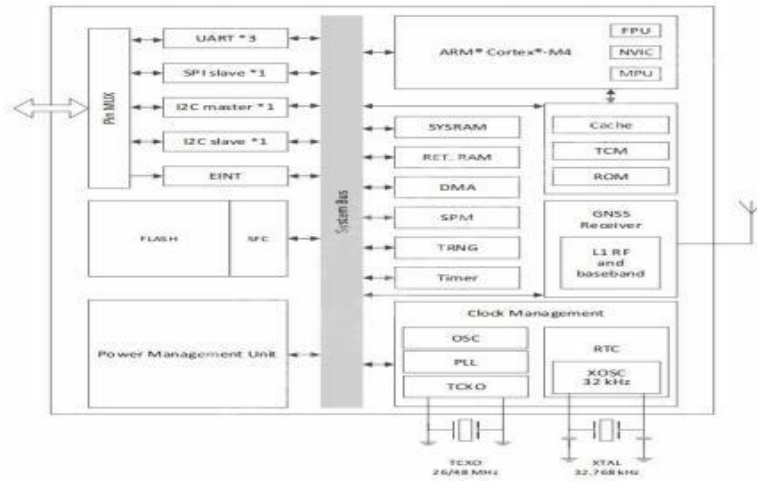

Figure 1: Block Diagram

## 2. Application

The module is equipped with a 24-pin SMT pad that connects to your application platform. Sub-interfaces included in the pad are described in details in the following chapters.

### 2.1. Pin Assignment

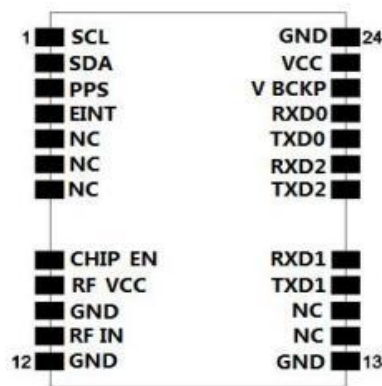

Figure 2: Pin Assignment

## 2.2. Pin Definition

Pin	Pin name	Description	Pin	Pin name	Description
1	SCL	NC	13	GND	Power GND
2	SDA	NC	14	NC	
3	TIMEPULSE	Pulse output(seconds)	15	NC	
4	RTC_EINT	Interrupt pin; If the external high level is greater than 10ms, the module exits the RTC mode (Hang when not in use)	16	TXD1	Reserved Debugging port (Idle)
5	NC		17	RXD1	Reserved Debugging port (Idle)
6	NC		18	TXD2	Standby serial port output
7	NC		19	RXD2	Standby serial port input
8	RESET	RESET	20	TXD0	Serial port TX port
9	RF_VCC	Active antenna power supply	21	RXD0	Serial port RX port
10	GND	Power GND	22	V_BCKP	backup battery 2.8V--3.3V. leave it vacant when not in use
11	RF_IN	GPS_RF Input	23	VCC	Working voltage: 2.8-3.6V Recommended use: 3.3V
12	GND	Power GND	24	GND	Power GND

## 2.3. Electrical Specification

### Absolute Maximum Ratings

Parameter	Minimum	Maximum	Condition
Supply Voltage ( VCC)	-0.5	3.6	Volt
Input Pin Voltage	-0.5	VCC+0.5	Volt
Input Power at RF_IN		+20	dBm
Storage Temperature	-55	+100	degC

### Operating Conditions

Parameter	Min	Typ	Max	Unit
Supply Voltage ( VCC)	3	3.3	3.6	Volt
Acquisition Current ( exclude active antenna current)		12		mA
Tracking Current ( exclude active antenna current)		12		mA
<b>I/O port &amp; UART port working voltage :</b>				
Output Low Voltage	-		0.4	Volt
Output HIGH Voltage	2.4		-	Volt
Input LOW Voltage	0.3		0.7	Volt
Input HIGH Voltage	2.1		3.6	Volt
Input LOW Current	-10		10	uA
Input HIGH Current	-10		10	uA
RF Input Impedance (RFIN)		50		Ohm

**2.4. UART Interface**

The module provides one universal asynchronous receiver& transmitter serial port. The module is designed as DCE (Data Communication Equipment), following the traditional DCE-DTE (Data Terminal Equipment) connection. The module and the client (DTE) are connected through the signals shown in the following figure. It supports data baud-rate from 9600bps to 961200bps.

**UART port:**

TXD: Send data to the RXD1 signal line of DTE.

RXD: Receive data from the TXD1 signal line of DTE.

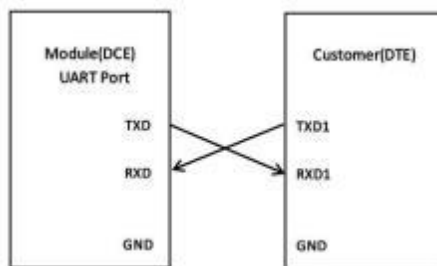
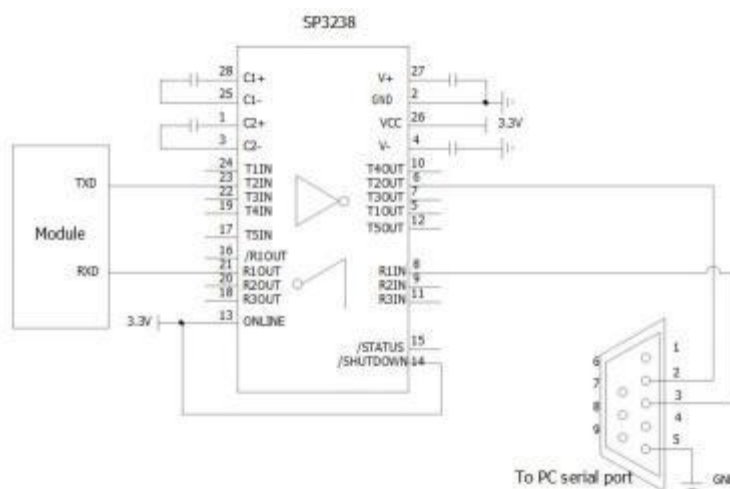

**Figure 3: Serial Port Connection**

**This UART port has the following features:**

- UART port can be used for NMEA Protocol output and proprietary commands input.
- The default output NMEA type setting is GGA, GLL, GSA, GSV, VTG, RMC, and ZDA.
- UART port supports the following data rates:  
9600, 14400, 19200, 38400, 57600, 961200bps.  
115200bps by default, 8 bits, no parity bit, 1 stop bit.
- Hardware flow control and synchronous operation are not supported.

The UART port does not support the RS-232 level but only CMOS level. If the module's UART port is connected to the UART port of a computer, it is necessary to add a level shift circuit between the module and the computer. Please refer to the following figure.



**Figure 4: RS-232 Level Shift Circuit**

### 3. Antenna Consideration

The EM1612-G is designed to use with active antenna, and passive antenna with higher antenna gain. Passive ceramic patch antenna is low-cost and provides good sensitivity. 50-ohm output larger size ceramic patch antenna with higher antenna gain can be connected directly to RF input of the module. Usually the ceramic patch

antenna and EM1612-G are mounted on opposite side of the PCB to reduce possibility of picking up digital noise. To improve signal reception performance, use larger ground plane under the patch antenna if possible; larger the ground plane, larger the overall antenna gain. The center frequency of the ceramic patch antenna changes with ground plane size. For optimal L1 operation, frequency bandwidth of the antenna needs to cover 1573MHz ~ 1606MHz respectively when mounted on the PCB. It is usual to ask the ceramic patch antenna vendor to select or tune a patch antenna that best matches the customer PCB.

Active antenna is essentially a passive antenna with built-in LNA and a coaxial cable to connect the antenna to the module. It has the flexibility of being located remotely from the module, but requires antenna power. Active antenna usually costs more than passive patch antenna, but the performance in low signal environments is usually better. Active antenna with gain of 10~20dB and noise figure less than 1.5dB can be used with EM1612-G.

Antenna Type	Passive	Active
GPS&QZSS Frequency (MHz)	1575.42 +/- 2 (L1)	1575.42 +/- 2 (L1)
BDS Frequency (MHz)	1561.098 +/- 2 (B1)	1561.098 +/- 2 (B1)
GLONASS Frequency (MHz)	1602MHz +/- 4 (L1)	1602MHz +/- 4 (L1)
GALILEO Frequency (MHz)	1575.42 +/- 2 (E1)	1575.42 +/- 2 (E1)
VSWR	< 2 (typical)	< 2 (typical)
Polarization	RHCP	RHCP
Antenna Gain	> 0dBi	> -2dBi
LNA Gain		20dB (typical)
Noise Figure		< 1.5dB
Total Gain		> 18dBi

### 4. Power Supply Requirement

EM1612-G requires a stable power supply, avoid ripple on VCC pin (<50mVpp). Power supply noise can affect the receiver's sensitivity. Bypass capacitors of 10uF and 0.1uF is recommended to be placed close to the module VCC pin; the values could be adjusted according to the amount and type of noise present on the supply line.

### 5. Backup Supply

The purpose of backup supply voltage pin (VBAT) is to keep the SRAM memory and the RTC powered when the module is powered down. This enables the module to have a faster time-to-first-fix when the module is powered on again. The backup current drain is less than 50µA. In normal powered on state, the internal processor access the SRAM and current drain is higher in active mode.

## 6.1PPS Output

When using four or more satellites for 3D positioning, the rising edge of the pulse generating 1 pulse per second (Duration: 800 seconds) on 1PPS pins is aligned with the UTC seconds, and the accuracy is about 20nS. When it is not positioned, it outputs a constant low pulse.

## 7. Layout Guidelines

### Separate RF and digital circuits into different PCB regions.

It is necessary to maintain 50-ohm impedance throughout the entire RF signal path. Try keeping the RF signal path as short as possible.

Do not route the RF signal line near noisy sources such as digital signals, oscillators, switching power supplies, or other RF transmitting circuit. Do not route the RF signal under or over any other components (including EM1612-G), or other signal traces. Do not route the RF signal path on an inner layer of a multi-layer PCB to minimize signal loss. Avoid sharp bends for RF signal path. Make two 45-deg bends or a circular bend instead of a single 90-degree bend if needed.

Avoid vias with RF signal path whenever possible. Every via adds inductive impedance. Vias are acceptable for connecting the RF grounds between different layers. Each of the module's ground pins should have short trace tying immediately to the ground plane below through a via.

The bypass capacitors should be low ESR ceramic types and located directly adjacent to the pin they are for.

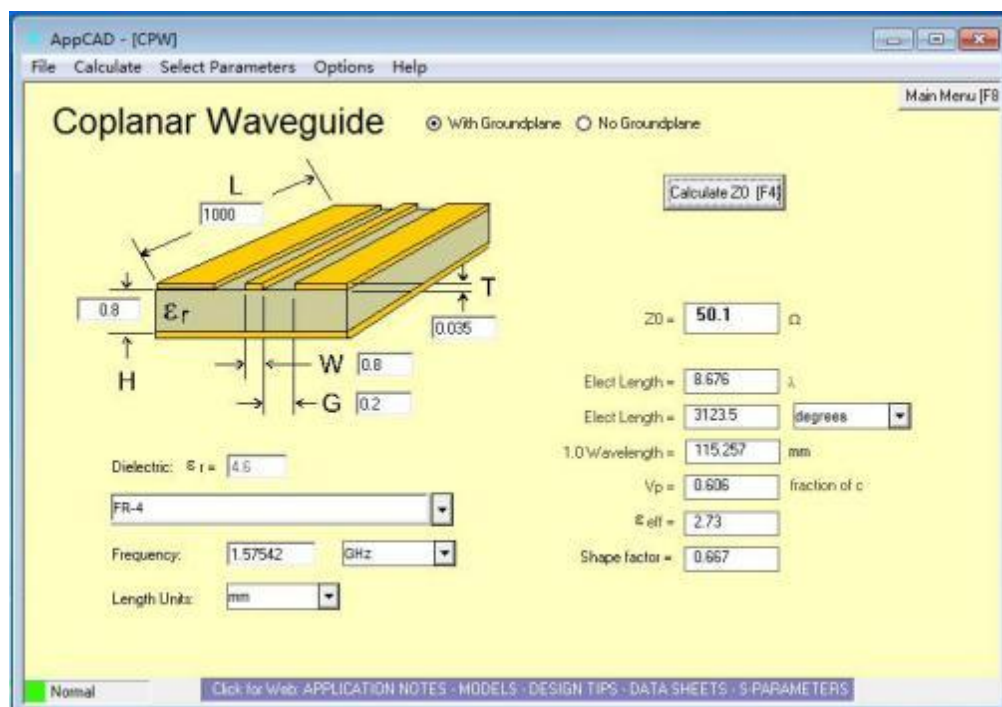

**Figure 5:** Antenna Design



## 8. ESD handling precautions

EM1612-G series modules are Electrostatic Sensitive Devices (ESD). Observe precautions for handling! Failure to observe these precautions can result in severe damage to the GPS receiver!

GPS receivers are Electrostatic Sensitive Devices (ESD) and require special precautions when handling. Particular care must be exercised when handling patch antennas, due to the risk of electrostatic charges. In addition to standard ESD safety practices, the following measures should be taken into account whenever handling the receiver:

- ❖ Unless there is a galvanic coupling between the local GND(i.e. the work table) and the PCB GND, then the first point of contact when handling the PCB must always be between the local GND and PCB GND.
- ❖ Before mounting antenna patch, connect ground of the device. When handling the RF pin, do not come into contact with any charged capacitors and be careful when contacting materials that can develop charges (e.g. patch antenna ~10pF, coax cable ~50-80pF/m, soldering iron.. ...)
- ❖ To prevent electrostatic discharge through the RF input, do not touch any exposed antenna area. If there is any risk that such exposed antenna area is touched in non ESD protected work area, implement proper ESD protection measures in the design.
- ❖ When soldering RF connectors and patch antennas to the receiver's RF pin, make sure to use an ESD safe soldering iron (tip).



**Table 1: ESD Endurance Table (Temperature : 25°C, Humidity: 45%)**

Pin	Contact Discharge	Air Discharge
RF_IN	±5KV	± 10KV
VCC	±5KV	± 10KV
UART	±3KV	±6KV
Others	±2KV	±4KV



**9. Mechanical Dimensions**

2.2 This chapter describes the mechanical dimensions of the module.

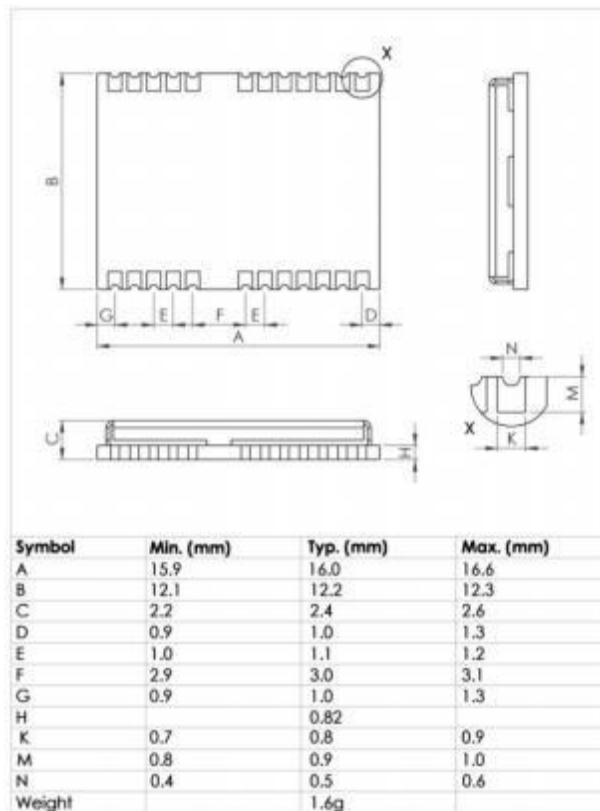

**Figure2: Mechanical Dimensions (Unit: mm)**

**2.3 Reference Charging Size for PCB (unit: mm)**

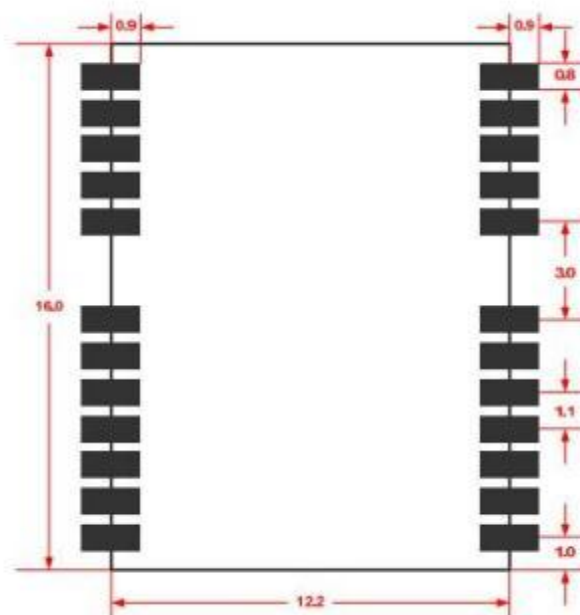
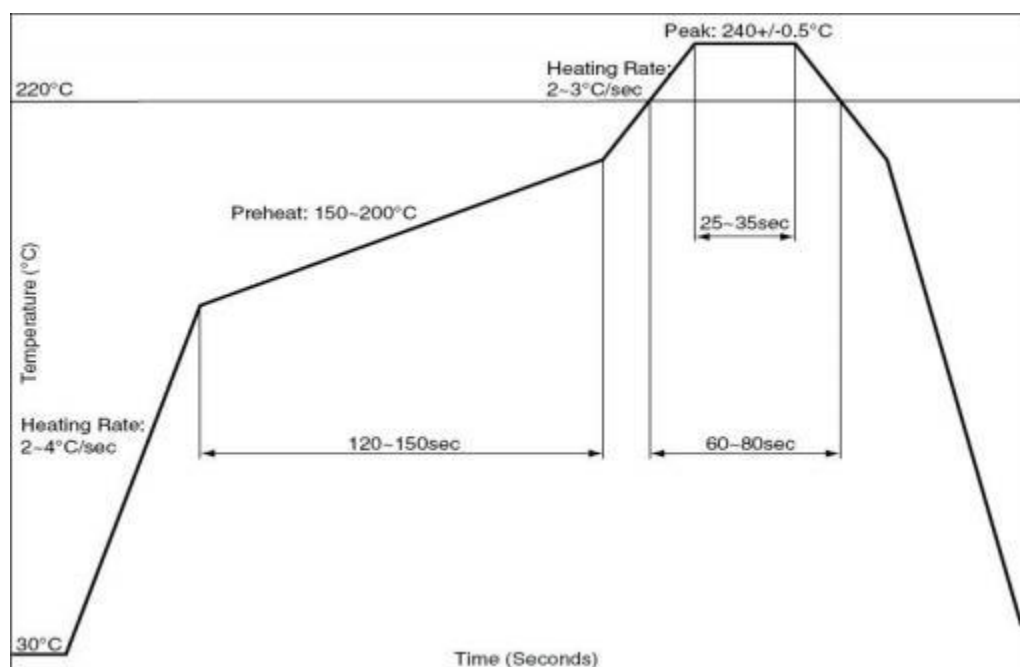

**Figure 4: Reference Charging Size for PCB (unit: mm)**

## 10 .Manufacturing, Packaging and Ordering Information

### 10.1. Assembly and Soldering

EM1612-G module is intended for SMT assembly and soldering in a Pb-free reflow process on the top side of the PCB. It is suggested that the minimum height of solder paste stencil is 100 um to ensure sufficient solder volume. Pad openings of paste mask can be increased to ensure proper soldering and solder wetting over pads. It is suggested that the peak reflow temperature is 220~240°C (for SnAg3.0Cu0.5 alloy). The absolute maximum reflow temperature is 260°C. To avoid damage to the module when it is repeatedly heated, it is suggested that the module should be mounted after reflow soldering for the other side of PCB has been completed. Recommended reflow soldering thermal profile is shown below:



**Figure 7:** Recommended Reflow Soldering Thermal Profile

### 10.2. Moisture Sensitivity

EM1612-G module is sensitive to moisture. To prevent EM1612-G from permanent damage during reflow soldering, baking before reflow soldering is required in following cases:

- ❖ Humidity indicator card: One or more indicating spots are no longer blue.
- ❖ The seal is opened and the module is exposed to excessive humidity.

EM1612-G shall be baked for 192 hours in a cryogenic environment at 40°C+5°C/-0°C and <5%RH, or for 24 hours in a high-temperature environment at 125°C±5°C. As the plastic packaging tape is not heat-resistant, the module should be removed from the tape before baking, otherwise, the tape will be damaged due to high temperature heating, you can also refer to the actual production technology of the SMT factory.

**10.3. Tape and Reel Packaging**

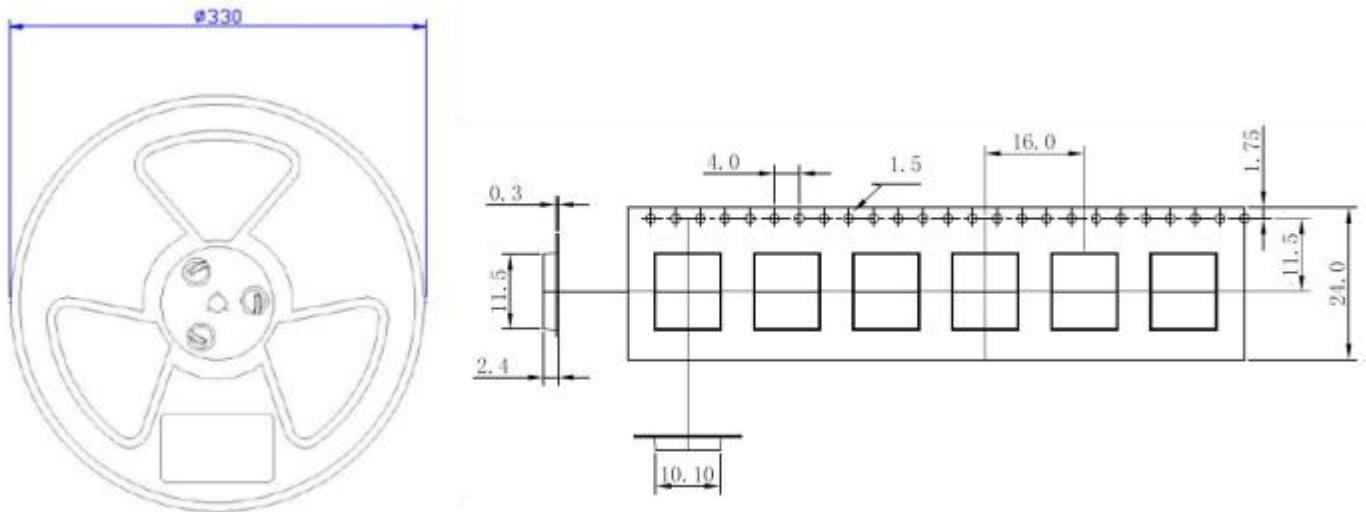

Unit: mm

Quantity per reel: 1000pcs

Length per reel: 16m

**Figure 12: Tape and Reel**



**Figure 13: Packaging physical Figure**

**Table 8: Reel Packaging**

Model Name	MOQ for MP	Minimum Package: 1000pcs
EM1612-G	1000pcs	Size: 365mm × 350mm × 53mm N.W: 0.87kg G.W: 1.05kg

## 11. NMEA 0183 Protocol

The output protocol supports NMEA-0183 standard. The implemented messages include GGA, GLL, GSA, GSV, VTG, RMC, and ZDA messages. The NMEA message output has the following sentence structure:

\$AACCC , c-c\*hh

The detail of the sentence structure is explained in Table 1.

**Table 3: The NMEA sentence structure**

character	HEX	Description
“\$”	24	Start of sentence.
Aaccc		Address field. “aa” is the talker identifier. “ccc” identifies the sentence type.
“,”	2C	Field delimiter.
C–c		Data sentence block.
“*”	2A	Checksum delimiter.
Hh		Checksum field.
<CR><LF>	0D0A	Ending of sentence. (carriage return, line feed)

**Table 4: Overview of NMEA messages**

<b>\$GNGGA</b>	Time, position, and fix related data of the receiver.
<b>\$GNGLL</b>	Position, time and fix status.
<b>\$GNGSA</b>	Used to represent the ID of satellites which are used for position fix. When GPS&GLONASS&Galileo & BDS satellites are used for positioning solutions, the ID of available positioning satellites is counted and output with multiple statements.
<b>\$GPGSV</b> <b>\$GLGSV</b> <b>\$GAGSV</b> <b>\$GBGSV</b>	Satellite information about elevation, azimuth and CNR, satellites are used in position solution, a \$GPGSV sentence is used for GPS satellites, a \$GLGSV sentence is used for GLONASS satellites, a \$GAGSV sentence is used for GALILEO satellites. And \$BDGSV sentence is used for BDS satellites.
<b>\$GNRMC</b>	Time, date, position, course and speed data.
<b>\$GNVTG</b>	Course and speed relative to the ground.
<b>\$GNZDA</b>	UTC, day, month and year and time zone.

The formats of the supported NMEA messages are described as follows:

### 11.1 GGA – Global Positioning System Fix Data

Time, position and fix related data for a GNSS receiver.

Structure:

\$GNGGA,hhmmss.sss,ddmm.mmmm,a,dddmm.mmmm,a,x,xx,x.x,x.x,M,x.x,M,x.x,xxxx\*hh

For example:

\$GNGGA,175258.000,2447.0870,N,12100.5221,E,2,15,0.7,95.2,M,19.6,M,,0000\*72

Field	Name	Example	Description
1	UTC Time	175258.000	UTC of position in hhmmss.sss format, (000000.000 ~ 235959.999)
2	Latitude	2447.08700	Latitude in ddmm.mmmmm format Leading zeros transmitted
3	N/ S Indicator	N	Latitude hemisphere indicator, ‘N’ = North, ‘S’ = South
4	Longitude	12100.52210	Longitude in dddmm.mmmmm format Leading zeros transmitted

5	E/W Indicator	E	Longitude hemisphere indicator, 'E' = East, 'W' = West
6	Quality Indicator	2	Quality Indicator 0: position fix unavailable 1: valid position fix, SPS mode 2: valid position fix, differential GPS mode 3: GPS PPS Mode, fix valid 6: Estimated (dead reckoning) Mode
7	Satellites Used	15	Number of satellites in use, (00 ~ 56)
8	HDOP	0.7	Horizontal dilution of precision, (0.0 ~ 99.9)
9	Altitude	95 2	mean sea level ( geoid), (
10	Geoidal Separation	19.6	Geoidal separation in meters
11	Age pf Differential GPS data		Age of Differential GPS data NULL when DGPS not used
12	DGPS Station ID	0000	Differential reference station ID, 0000 ~ 1023
13	Checksum	72	

## 11.2 GLL – Latitude/Longitude

Latitude and longitude of current position, time, and status.

Structure:

\$GNGLL,ddmm.mmmm,a,dddmm.mmmm,a,hhmmss.sss,A,a\*hh

For example:

\$GNGLL,2447.0870,N,12100.5221,E,175258.000,A,D\*42

Field	Name	Example	Description
1	Latitude	2447.08700	Latitude in ddmm.mmmmm format Leading zeros transmitted
2	N/S Indicator	N	Latitude hemisphere indicator 'N' = North 'S' = South
3	Longitude	12100.52210	Longitude in dddmm.mmmmm format Leading zeros transmitted
4	E/W Indicator	E	Longitude hemisphere indicator 'E' = East 'W' = West
5	UTC Time	175258 000	UTC time in hhmmss sss format (000000 000 ~ 235959 999)
6	Status	A	Status, 'A' = Data valid, 'V' = Data not valid
7	Mode Indicator	D	Mode indicator 'N' = Data not valid 'A' = Autonomous mode 'D' = Differential mode 'E' = Estimated (dead reckoning) mode
8	Checksum	42	

### 1.3 GSA – GNSS DOP and Active Satellites

GNSS receiver operating mode, satellites used in the navigation solution reported by the GGA sentence and DOP values.

Structure:

\$GNGSA,A,x,xx,xx,xx,xx,xx,xx,xx,xx,xx,xx,xx,x.x,x.x,x.x,x\*hh

For example:

\$GNGSA,A,3,21, 12, 15, 18,20,24, 10,32,25, 13,, 1.2,0.7, 1.0, 1\*18

Field	Name	Example	Description
1	Mode	A	Mode 'M' = Manual, forced to operate in 2D or 3D mode 'A' = Automatic, allowed to automatically switch 2D/3D
2	Mode	3	Fix type 1 = Fix not available 2 = 2D 3 = 3D
3	Satellite used 1~ 12	21, 12, 15, 18, 20, 24, 10, 32, 25, 13	01 ~ 32 are for GPS; 33 ~ 64 are for WAAS (PRN minus 87); 193 ~ 197 are for QZSS; 65 ~ 88 are for GLONASS (GL PRN) ; 01 ~ 36 are for GALILEO (GA PRN); 01 ~ 37 are for BDS (BD PRN). GPS, GLONASS, GALILEO and BDS satellites are differentiated by the GNSS system ID in table 3. Maximally 12 satellites are included in each GSA sentence
4	PDOP	1.2	Position dilution of precision (0.0 to 99.9)
5	HDOP	0.7	Horizontal dilution of precision (0.0 to 99.9)
6	VDOP	1.0	Vertical dilution of precision (0.0 to 99.9)
7	GNSS System ID	1	1 for GPS, 2 for GLONASS, 3 for GALILEO, 4 for BDS
8	Checksum	18	

### 11.4 GSV – GNSS Satellites in View

Number of satellites (SV) in view, satellite ID numbers, elevation, azimuth, and SNR value. Four satellites maximum per transmission.

Structure:

\$GPGSV , x , x , xx , xx , xx , xx , xx , ... , xx , xx , xx , xx , xx , x\*hh

For example :

\$GPGSV , 4, 1 , 13 , 02,72 , 109 , 43,24 , 69,035 , 48, 18 , 52,330 , 42,21 , 49,246 , 43 , 1\*69

Field	Name	Example	Description
1	Number of message	4	Total number of GSV messages to be transmitted (1 - 5)
2	Sequence number	1	Sequence number of current GSV message
3	Satellites in view	13	Total number of satellites in view (00 ~ 20)
4	Satellite ID	02	01 ~ 32 are for GPS; 33 ~ 64 are for WAAS (PRN minus 87); 193 ~ 197 are for QZSS; 65 ~ 88 are for GLONASS (GL PRN) ; 01 ~ 36 are for GALILEO (GA PRN); 01 ~ 37 are for BDS (BD PRN). GPS, GLONASS, GALILEO and BDS satellites are differentiated by the GNSS system ID in table 3. Maximally 12 satellites are included in each GSA sentence
5	Elevation	72	Satellite elevation in degrees, (00 ~ 90)

6	Azimuth	109	Satellite azimuth angle in degrees, (000 ~ 359 )
7	SNR	43	C/No in dB (00 ~ 99) Null when not tracking
8	Signal ID	1	1 for L1/CA
9	Checksum	69	

### 11.5 RMC – Recommended Minimum Specific GNSS Data

Time, date, position, course and speed data provided by a GNSS navigation receiver.

Structure:

\$GNRMC,hhmmss.sss,A,dddmm.mmmm,a,dddmm.mmmm,a,x.x,x.x,ddmmy,.,a\*h

h For example:

\$GNRMC,175258.000,A,2447.0870,N,12100.5220,E,000.0,000.0,220617,.,D\*75

Field	Name	Example	Description
1	UTC time	175258.000	UTC time in hhmmss.sss format (000000.00 ~ 235959.999)
2	Status	A	Status 'V' = Navigation receiver warning 'A' = Data Valid
3	Latitude	2447.08700	Latitude in dddmm.mmmmm format Leading zeros transmitted
4	N/S indicator	N	Latitude hemisphere indicator 'N' =North 'S' = South
5	Longitude	12100.52210	Longitude in dddmm.mmmmm format Leading zeros transmitted
6	E/W Indicator	E	Longitude hemisphere indicator 'E' = East 'W' = West
7	Speed over ground	000.0	Speed over ground in knots (000.0 ~ 999.9)
8	Course over ground	000.0	Course over ground in degrees (000.0 ~ 359.9)
9	UTC Date	220617	UTC date of position fix, ddmmyy format
10	Mode indicator	D	Mode indicator 'N' = Data not valid 'A' = Autonomous mode 'D' = Differential mode 'E' = Estimated (dead reckoning) mode
11	checksum	75	

### 11.6 VTG – Course Over Ground and Ground Speed

The actual course and speed relative to the ground.

Structure:

GNVTG,x.x,T,,M,x.x,N,x.x,K,a\*hh

For example:

\$GNVTG,000.0,T,,M,000.0,N,000.0,K,D\*16



Field	Name	Example	Description
1	Course	000.0	True course over ground in degrees (000.0 ~ 359.9)
2	Speed	000.0	Speed over ground in knots (000.0 ~ 999.9)
3	Speed	000.0	Speed over ground in kilometers per hour (000.0 ~ 1800.0)

4	Mode	D	Mode indicator 'N' = Data not valid 'A' = Autonomous mode 'D' = Differential mode 'E' = Estimated (dead reckoning) mode
5	Checksum	16	

### 11.7 ZDA – TIME AND DATE

UTC, day, month, year and local time zone

Structure:

\$GNZDA,hhmmss.sss,xx,xx,xxxx,xx,xx\*hh<CR><LF>

For example:

\$GNZDA,175258.000,22,06,2017,00,00\*46<CR><LF>

Field	Name	Example	Units	Description
1	UTC time	175258.000		UTC time in hhmmss.ss format (000000.00 ~ 235959.99)
2	UTC Day	22		UTC time: day (01 ~ 31)
3	UTC Month	06		UTC time: month (01 ~ 12)
4	UTC Year	2017		UTC time: year (4 digit format)
5	Local zone hour	00		Local zone hours (00 ~ +/- 13)
6	Local zone minutes	00		Local zone minutes (00 ~59)
7	Checksum	46		Checksum