

General Description

Delin EU1010 is a complete GPS engine module that features super sensitivity, ultra low power and small form factor. The GPS signal is applied to the antenna input of module, and a complete serial data message with position, velocity and time information is presented at the serial interface with NMEA protocol or custom protocol.

Its -165dBm tracking sensitivity extends positioning coverage into place like urban canyons and dense foliage environment where the GPS was not possible before. The small form factor and low power consumption make the module easy to integrate into portable device like PNDs, mobile phones, cameras and vehicle navigation systems.

Applications

- LBS (Location Based Service)
- PND (Portable Navigation Device)
- Vehicle navigation system
- Mobile phone



Figure: EU1010 Top View

Features

- Build on high performance, low-power ublox UBX-G7020-KT chip set
- Ultra high Track sensitivity: -165dBm
- Extremely fast TTFF at low signal level
- Low power consumption: Max 25mA@3.3V
- NMEA-0183 compliant protocol or custom protocol
- Operating voltage: 2.8V to 3.6V
- Operating temperature range:-40to85°C
- SMD type with stamp holes
- Small form factor: 10.1x9.7x2.2mm
- RoHS compliant (Lead-free)

1 Functional description	3
1.1 Overview	3
1.2. Key Features	4
1.2. Block Diagram	5
2 Application	5
2.1. Pin Assignment	5
2.2. Pin Definition	6
2.3. Power Supply	7
2.4. UART Interface	9
3 Antenna Interfaces	10
3.1. PCB Design Guide	10
3.2. External Active Antenna	11
4. Configuration instruction Explain	12
5 Electrical, Reliability and Radio Characteristics	14
5.1. Absolute Maximum Ratings	14
5.2. Operating Conditions	14
5.3. Current Consumption	15
5.4. ESD handling precautions	15
6 Mechanical Dimensions	16
7 Manufacturing, Packaging and Ordering Information	17
7.1. Assembly and Soldering	17
7.2. Moisture Sensitivity	17
7.3. Tape and Reel Packaging	18
8 Appendix References	19
9 NMEA 0183 Protocol	20
9.1 GGA-Global Positioning System Fixed Data	21
9.2 GLL-Geographic Position – Latitude/Longitude	22
9.3 GSA-GNSS DOP and Active Satellites	22
9.4 GSV-GPS Satellites in View	23
9.5 RMC-Recommended Minimum Specific GNSS Data	23
9.6 VTG-Course Over Ground and Ground Speed	24

1 Functional description

1.1 Overview

Delin EU1010series of standalone concurrent GPS modules is built on the exceptional performance of the u-blox 7 GPS (GPS, GLONASS, QZSS and SBAS) engine in the industry proven form factor.

Delin EU1010series provides high sensitivity and minimal acquisition times while maintaining low system power. The EU1010is optimized for cost sensitive applications, while EU1010provides best performance and easier RF integration. The form factor allows easy migration from previous generations. Sophisticated RF-architecture and interference suppression ensure maximum performance even in GPS-hostile environments.

EU1010modules use ublox-7 GPS chips qualified according to AEC-Q100, are manufactured in ISO/TS 16949 certified sites, and fully tested on a system level. Qualification tests are performed as stipulated in the ISO16750 standard: “Road vehicles – Environmental conditions and testing for electrical and electronic equipment”.

EU1010modules support the u-blox Assist Now Online and Assist Now Offline A-GPS and are OMA SUPL compliant. u-blox’ AssistNow Assistance supply aiding information, such as ephemeris, almanac, rough last position and time, reduce the time to first fix significantly and improve the acquisition sensitivity. AssistNow data are with u-blox 7 supporting both GPS constellation for faster acquisition than a GPS-only assistance. The extended validity of AssistNow Offline data (up to 35 days) and AssistNow Autonomous data (up to 6 days) provide faster acquisition after long off time.

Made of lead-free technology, conforms to the RoHS standard, Single patch, two times more rapid application of SMT scheme.

1.2. Key Features

Table 1: Key Features

Parameter	Specification
Power Supply	<ul style="list-style-type: none"> Supply voltage: 2.8V~3.6V Typical: 3.3V
Power Consumption	<ul style="list-style-type: none"> Acquisition: 25mA @VCC=VBAT=3.3V Tracking: 20mA @VCC=VBAT=3.3V Backup: 15uA @VBAT=3.3V
Receiver Type	<ul style="list-style-type: none"> Code 56 search channels ,22 synchronous tracking channels GPS&QZSS L1 1575.42MHz C/A , GLONASS L1OF 1602MHz, SBAS: WAAS, EGNOS, MSAS, GAGAN
Sensitivity	<ul style="list-style-type: none"> Tracking: -165dBm Re-acquisition: -156dBm Acquisition: -146dBm
TTFF (Autonomous)	<ul style="list-style-type: none"> Cold start: 35s typ @-130dBm Warm start: 30s typ @-130dBm Hot start: 1s typ @-130dBm
Horizontal Position Accuracy (Autonomous)	<ul style="list-style-type: none"> <2.5m CEP @-130 dBm
Max Update Rate	<ul style="list-style-type: none"> Up to 10Hz,1Hz by fault
Accuracy of 1PPS Signal	<ul style="list-style-type: none"> This module 1PPS hardware is not enabled
Acceleration Accuracy	<ul style="list-style-type: none"> Without aid: 0.1m/s²
Dynamic Performance	<ul style="list-style-type: none"> Maximum altitude: 18,000m Maximum velocity: 515m/s Acceleration: 4G
UART Port	<ul style="list-style-type: none"> UART Port: TXD and RXD Supports baud rate from 4800bps to 115200bps, 9600bps by default UART port for NMEA and UBX output, binary or ublox proper Agreement input
Temperature Range	<ul style="list-style-type: none"> Normal operation: -40°C ~ +85°C Storage temperature: -45°C ~ +125°C
Physical Characteristics	<ul style="list-style-type: none"> Size: 10.1±0.15 × 9.7±0.15 × 2.2±0.1mm Weight: Approx. 0.41g

1.2. Block Diagram

The following figure shows a block diagram of EU1010module. It consists of a single chip GPS IC which includes the RF part and Baseband part, a SAW filter, a TCXO, a crystal oscillator.

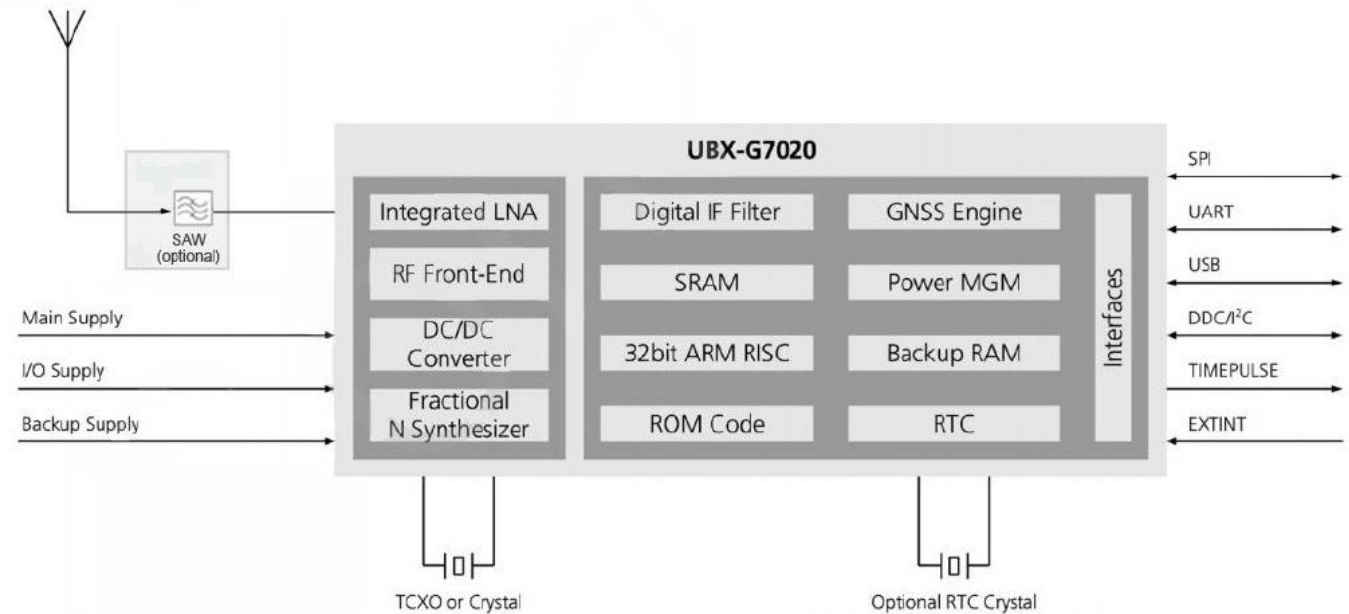

Figure 1: Block Diagram

2 Application

The module is equipped with a 10-pin SMT pad that connects to your application platform. Sub-interfaces included in the pad are described in details in the following chapters.

2.1. Pin Assignment

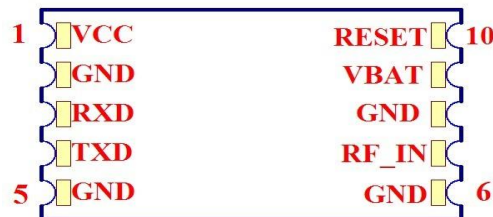

Figure 2: Pin Assignment

2.2. Pin Definition

Power Supply					
Pin Name	Pin No.	I/O	Description	DC Characteristics	Comment
VCC	1	I	Main power supply	V _{max} =3.6V V _{min} =2.8V V _{nom} =3.3V	Supply current not less than 100mA.
VBAT	9	I	Backup power supply	V _{max} =3.6V V _{min} =1.8V V _{nom} =3.3V	Supply power for RTC domain. The VBAT pin can be directly supplied power by battery or connect it to VCC.
GND	2.5.6.8	G	Ground.		Assure a good GND connection to all GND pins of the module, preferably with a large ground plane.
UART Port					
Pin Name	Pin No.	I/O	Description	DC Characteristics	Comment
RXD	3	I	Receive data	V _{ILmin} =-0.3V V _{ILmax} =0.8V V _{IHmin} =2.0V V _{IHmax} =3.6V	
TXD	4	O	Transmit data	V _{OLmin} =-0.3V V _{OLmax} =0.4V V _{OHmin} =2.4V V _{OHmax} =3.1V	
RF Interface					
Pin Name	Pin No.	I/O	Description	DC Characteristics	Comment
RF_IN	7	I	External active antenna RF input		Characteristic impedance of 50Ω
Reset					
Pin Name	Pin No.	I/O	Description	DC Characteristics	Comment
RESET	10	I	System reset	V _{ILmin} =-0.3V V _{ILmax} =0.8V V _{IHmin} =2.0V V _{IHmax} =3.6V	Low level active. If unused, keep this pin open or connect it to VCC.

2.3. Power Supply

VCC pin supplies power for BB, RF, I/O, Antenna. The load current of VCC varies according to the VCC level, processor load, the number of tracked satellites and the rate of satellite re-acquisition. Using external active antenna will consume additional 11mA from our module. So it is important to supply sufficient current and make the power clean and stable. VCC supply ripple voltage should meet the requirement: 54mV (RMS) max @f=0…3MHz and 15mV (RMS) max@f>3MHz. You should choose the LDO without built-in output high-speed discharge function to keep long output voltage drop-down period. The decouple combination of 10uF and 100nF capacitor is recommended nearby VCC pin.

The VBAT pin supplies power for RTC domain. It should be valid when power on the module. The voltage of RTC domain ranges from 1.8V to 3.6V. In order to achieve a better TTFF, RTC domain should be valid all the time. It can supply power for SRAM memory in RTC domain which contains all the necessary GPS information for quick start-up and a small amount of user configuration variables.

✧ The module's internal power construction is shown as below.

VCC supplies power for PMU, and VBAT supplies power for RTC domain. TIMER signal highlighted in red in the following figure belongs to RTC domain and can be used to control the power switch on/off.

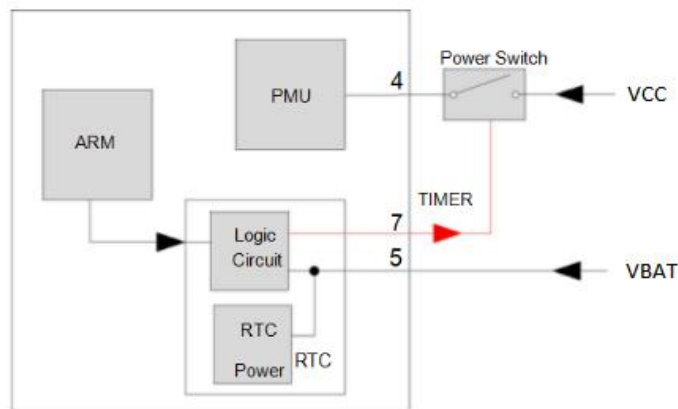

Figure 3: Internal Power Construction

✧ Power supply solutions for EU1010module are listed as the following.

The simplest power circuit for EU1010module is 3.3V power source connected to VCC pin and VBAT pin of the module directly. In this case, once you powered on the module, the full cold start will be implemented.

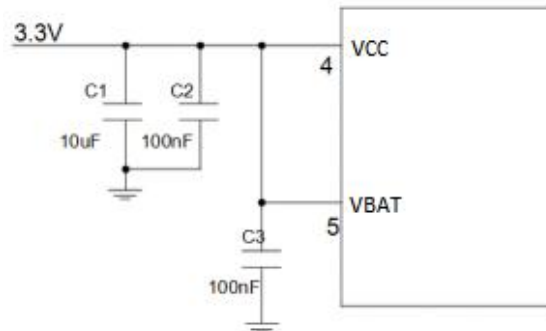

Figure 4: Reference Circuit for Power Supply

✧ If your power supply circuit adopts the design mentioned above , EU1010module does not support backup mode.

The other way is feeding VBAT through a backup battery directly. The module will enter into backup mode when power source (3.3V) is cut off. Furthermore, it is necessary to add an external charging circuit for rechargeable battery. The detailed schematic (mount R2 with 0R to replace Power switch) is shown as there is no charge source when power source (3.3V) is cut off. MS621FE FL11E from Seiko is recommended. The consumption of VBAT is as low as 7µA in backup mode.

The schematic with power supply circuit is shown as below. As power source (3.3V) is always valid and the battery is charged continuously, the capacity of the battery can be small. The detailed schematic for power switch circuit is shown in *Figure 5*.

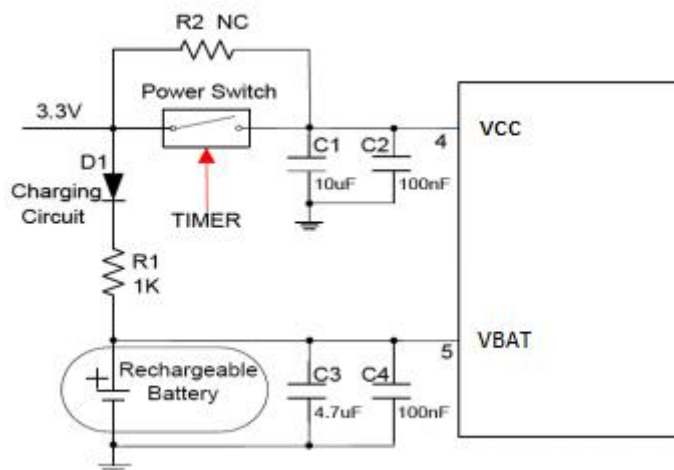

Figure 5: Reference Charging Circuit for Chargeable Battery

VCC does not supply power for RTC domain in EU1010module, so the VBAT pin must be powered externally.

Furthermore, it is strongly recommended to supply power to VBAT through a backup battery, which can ensure EU1010module improves TTFF after next restart. For details about TTFF.

2.4. UART Interface

The module provides one universal asynchronous receiver& transmitter serial port. The module is designed as DCE (Data Communication Equipment), following the traditional DCE-DTE (Data Terminal Equipment) connection. The module and the client (DTE) are connected through the signals shown in the following figure. It supports data baud-rate from 4800bps to 115200bps.

UART port:

TXD: Send data to the RXD1 signal line of DTE.

RXD: Receive data from the TXD1 signal line of DTE.

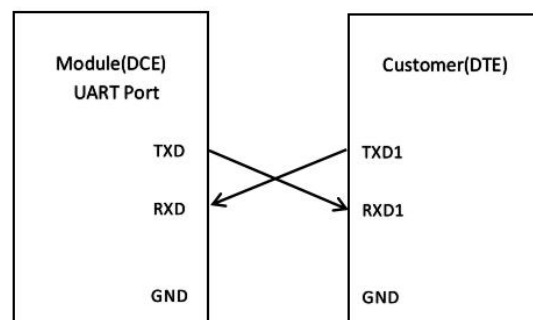

Figure 6: Connection of Serial Interfaces

This UART port has the following features:

- UART port can be used for NMEA output and proprietary commands input.
- The default output NMEA type setting is RMC, GGA, GSA, GSV, VTG, GLL
- UART port supports the following data rates:
4800, 9600, 14400, 19200, 38400, 57600, 115200bps.
The default setting is 9600bps, 8 bits, no parity bit, 1 stop bit.
- Hardware flow control and synchronous operation are not supported.

The UART port does not support the RS-232 level but only CMOS level. If the module's UART port is connected to the UART port of a computer, it is necessary to add a level shift circuit between the module and the computer. Please refer to the following figure.

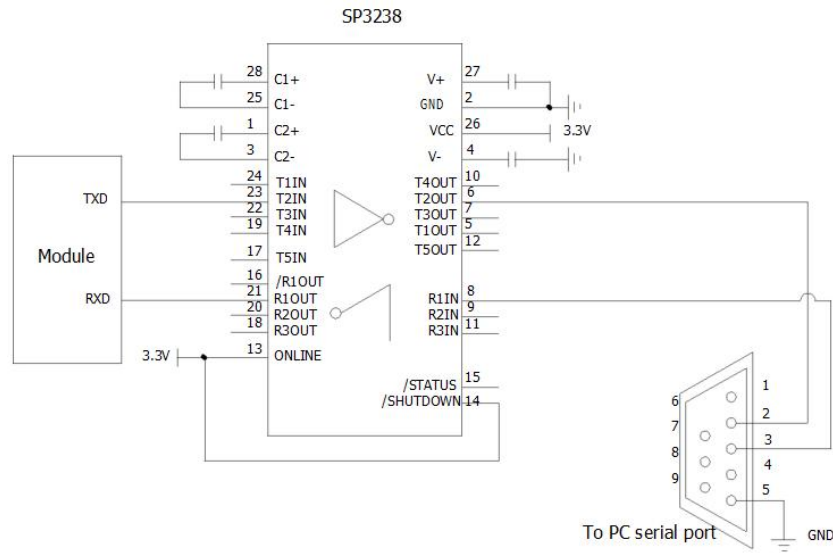

Figure 7: RS-232 Level Shift Circuit

3 Antenna Interfaces

3.1. PCB Design Guide

The EU1010GPS receiver is designed for supporting the active antenna or passive antenna connected with pin RF_IN. The gain of active antenna should be no less than 15dB. The maximum noise figure should be no more than 2.5dB and output impedance is at 50 Ohm.

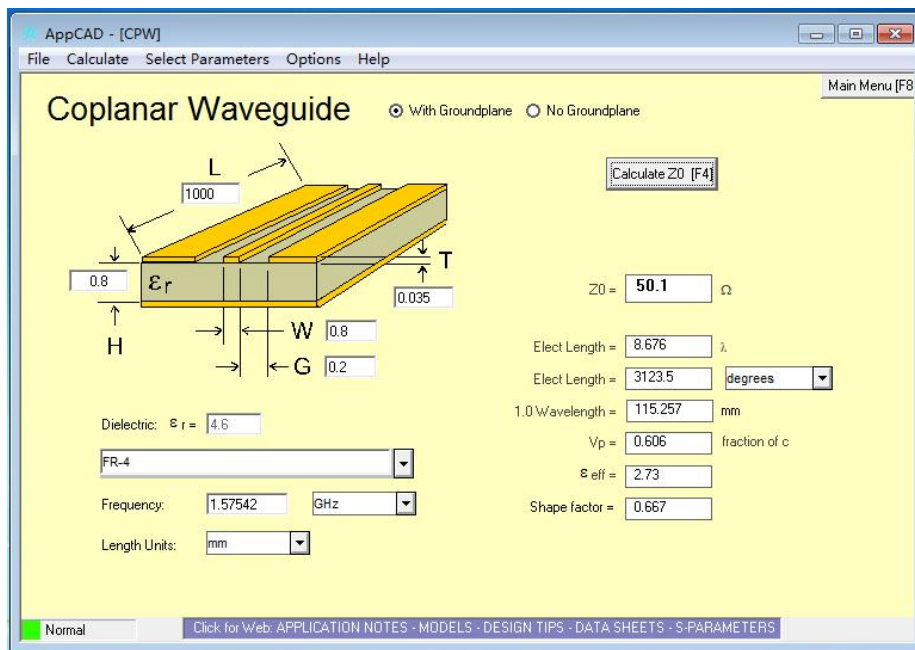

Figure 8: Antenna design requirements

3.2. External Active Antenna

The following figure is a typical reference design with active antenna. In this mode, DC on the VDD_3.3V pin is powered to power the external active antenna.

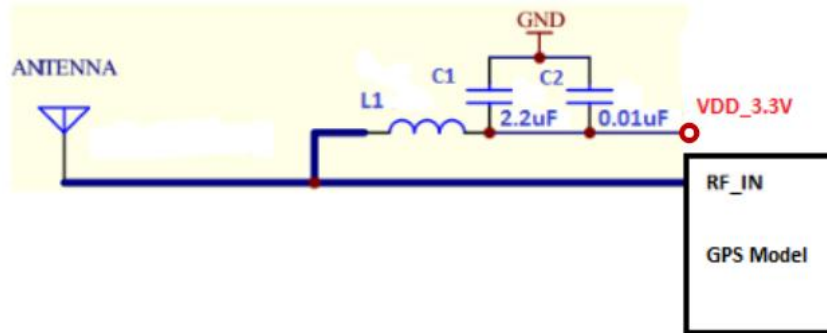

Figure 9: Reference Design for Active Antenna

C1, C2, L1 is used for power supply and filtering effect to the external active antenna, RF_IN antenna to a circuit part (BOLD line) for high frequency microstrip line, PCB in the design of this part of the line to calculate the characteristic impedance of the high-frequency line according to the principle of high frequency wiring.

- ◇ Requirements: this section of the line in the 1575.42MHz frequency characteristic impedance requirement is 50 ohm.

Table 2: The modules Antenna Specifications

Parameter	Specification	
Antenna Type	Passive and active antenna	
ActiveAntenna Recommendations	Minimum gain	15 dB (to compensate signal loss in RF cable)
	Maximum gain	50 ⁹ dB / 30 ¹⁰ dB
	Maximum noise figure	1.5 dB

4. Configuration instruction Explain

The module supports the commonly used commands in configuration, The following table describes some of the parameters of the UART port configuration command, baud rate setting: NMEA data refresh rate is set, the NMEA statement output set, positioning mode setting etc.

The Module power up initialization requires 300ms, Please send the sixteen system from CPU via serial port.

Table 3: Baud rate configuration command

Common commands	Instructions
Cold star	B5 62 06 04 04 00 FF FF 02 00 0E 61
Hot start	B5 62 06 04 04 00 00 00 02 00 10 68
Reset	B5 62 06 04 04 00 FF 87 01 00 95 F7
Restore factory settings	B5 62 06 09 0D 00 FF FF 00 00 00 00 00 00 FF FF 00 00 07 1F 9E
Save configuration	B5 62 06 09 0D 00 00 00 00 00 FF FF 00 00 00 00 00 00 17 31 BF
Baud rate is 4800bps	b5 62 06 00 14 00 01 00 00 00 d0 08 00 00 c0 12 00 00 07 00 07 00 00 00 00 00 d3 fc b5 62 06 00 01 00 01 08 22
Baud rate is 9600bps	b5 62 06 00 14 00 01 00 00 00 d0 08 00 00 80 25 00 00 07 00 07 00 00 00 00 00 a6 cd b5 62 06 00 01 00 01 08 22
Baud rate is 38400bps	b5 62 06 00 14 00 01 00 00 00 d0 08 00 00 00 96 00 00 07 00 07 00 00 00 00 00 97 a8 b5 62 06 00 01 00 01 08 22
Baud rate is 115200bps	b5 62 06 00 14 00 01 00 00 00 d0 08 00 00 00 c2 01 00 07 00 07 00 00 00 00 00 c4 96 b5 62 06 00 01 00 01 08 22
NMEA data refresh rate is 1Hz	B5 62 06 08 06 00 E8 03 01 00 01 00 01 39
NMEA data refresh rate is 2Hz	B5 62 06 08 06 00 F4 01 01 00 01 00 0B 77
NMEA data refresh rate is 4Hz	B5 62 06 08 06 00 FA 00 01 00 01 00 10 96
NMEA data refresh rate is 5Hz	B5 62 06 08 06 00 C8 00 01 00 01 00 DE 6A B5 62 06 08 00 00 0E 30
NMEA data refresh rate is 10Hz	B5 62 06 08 06 00 64 00 01 00 01 00 7A 12 B5 62 06 08 00 00 0E 30

Table4: NMEA statement content output configuration

Statement conten	Instructions
Close GGA OutPut	24 45 49 47 50 51 2c 47 47 41 2a 32 37 0d 0a b5 62 06 01 03 00 f0 00 00 fa 0f
Close GLL OutPut	24 45 49 47 50 51 2c 47 4c 4c 2a 32 31 0d 0a b5 62 06 01 03 00 f0 01 00 fb 11
Close GSA OutPut	24 45 49 47 50 51 2c 47 53 41 2a 33 33 0d 0a b5 62 06 01 03 00 f0 02 00 fc 13
Close GSV OutPut	24 45 49 47 50 51 2c 47 53 56 2a 32 34 0d 0a b5 62 06 01 03 00 f0 03 00 fd 15
Close RMC OutPut	24 45 49 47 50 51 2c 52 4d 43 2a 33 41 0d 0a b5 62 06 01 03 00 f0 04 00 fe 17
Close VTG OutPut	24 45 49 47 50 51 2c 56 54 47 2a 32 33 0d 0a b5 62 06 01 03 00 f0 05 00 ff 19
Open GGA OutPut	24 45 49 47 50 51 2c 47 47 41 2a 32 37 0d 0a b5 62 06 01 03 00 f0 00 01 fb 10
Open GLL OutPut	24 45 49 47 50 51 2c 47 4c 4c 2a 32 31 0d 0a b5 62 06 01 03 00 f0 01 01 fc 12
Open GSA OutPut	24 45 49 47 50 51 2c 47 53 41 2a 33 33 0d 0a b5 62 06 01 03 00 f0 02 00 fc 13
Open GSV OutPut	24 45 49 47 50 51 2c 47 53 56 2a 32 34 0d 0a b5 62 06 01 03 00 f0 03 00 fd 15
Open RMC OutPut	24 45 49 47 50 51 2c 52 4d 43 2a 33 41 0d 0a b5 62 06 01 03 00 f0 04 00 fe 17
Open VTG OutPut	24 45 49 47 50 51 2c 56 54 47 2a 32 33 0d 0a b5 62 06 01 03 00 f0 05 00 ff 19
GSV 5S Output once	B5 62 06 01 08 00 F0 03 00 05 00 00 00 00 07 51
Output only RMC	B56206010300F00100FB11B56206010300F00200FC13B56206010300F00300FD1 5B56206010300F00500FF19B56206010300F00000FA0F

5 Electrical, Reliability and Radio Characteristics

5.1. Absolute Maximum Ratings

Absolute maximum ratings for power supply and voltage on digital pins of the module are listed in the following table.

Table 5: Absolute Maximum Ratings

values within the specified boundaries by using appropriate protection diodes.

Parameter	Min.	Max.	Unit
Power Supply Voltage (VCC)	-0.3	3.6	V
Backup Battery Voltage (VBAT)	-0.3	3.6	V
Input Voltage at Digital Pins	-0.3	3.6	V
Input Power at RF_IN		15	dBm
Storage Temperature	-45	125	°C

- ✧ Stressing the device beyond the “Absolute Maximum Ratings” may cause permanent damage. These are stress ratings only. The product is not protected against over voltage or reversed voltage. If necessary, voltage spikes exceeding the power supply voltage specification, given in table above, must be limited to values within the specified boundaries by using appropriate protection diodes.

5.2. Operating Conditions

Table 6: Power Supply Ratings

Parameter	Description	Conditions	Min.	Typ.	Max.	Unit
VCC	Supply voltage	Voltage must stay within the min/max values, including voltage drop, ripple, and spikes.	2.8	3.3	3.6	V
IVCCP	Peak supply current	VCC=3.3V			100	mA
VBAT	Backup voltage supply		1.8	3.3	3.6	V
TOPR	Normal operating temperature		-40	25	80	°C

- ✧ The figure IVCCP can be used to determine the maximum current capability of power supply.

- ✧ Operation beyond the "Operating Conditions" is not recommended and extended exposure beyond the "Operating Conditions" may affect the device's reliability.

5.3. Current Consumption

The values for current consumption are shown in the following table.

Table 7: Current Consumption

Parameter	Conditions	Min.	Typ.	Max.	Unit
Ivcc @Acquisition	VCC=VBAT=3.3V		25		mA
Ivcc @Tracking	VCC=VBAT=3.3V		20		mA
Ivcc @Standby	VCC=VBAT=3.3V		2.0		mA
Ibckp @Backup	VBAT=3.3V		15		uA

The tracking current is tested in the following conditions:

- ✧ In Cold Start, 10 minutes after First Fix.
- ✧ In Hot Start, 15 seconds after First Fix.

5.4. ESD handling precautions

EU1010series modules are Electrostatic Sensitive Devices (ESD). Observe precautions for handling! Failure to observe these precautions can result in severe damage to the GPS receiver!

GPS receivers are Electrostatic Sensitive Devices (ESD) and require special precautions when handling. Particular care must be exercised when handling patch antennas, due to the risk of electrostatic charges. In addition to standard ESD safety practices, the following measures should be taken into account whenever handling the receiver:

- ✧ Unless there is a galvanic coupling between the local GND (i.e. the work table) and the PCB GND, then the first point of contact when handling the PCB must always be between the local GND and PCB GND.
- ✧ Before mounting antenna patch, connect ground of the device. When handling the RF pin, do not come into contact with any charged capacitors and be careful when contacting materials that can develop charges (e.g. patch antenna ~10pF, coax cable ~50-80pF/m, soldering iron, ...)
- ✧ To prevent electrostatic discharge through the RF input, do not touch any exposed antenna area. If there is any risk that such exposed antenna area is touched in non ESD protected work area, implement proper ESD protection measures in the design.



- ◇ When soldering RF connectors and patch antennas to the receiver's RF pin, make sure to use an ESD safe soldering iron (tip).

Table 8: ESD Endurance Table (Temperature : 25°C, Humidity: 45%)

Pin	Contact Discharge	Air Discharge
RF_IN	±5KV	±10KV
VCC	±5KV	±10KV
UART	±3KV	±6KV
Others	±2KV	±4KV

6 Mechanical Dimensions

This chapter describes the mechanical dimensions of the module.

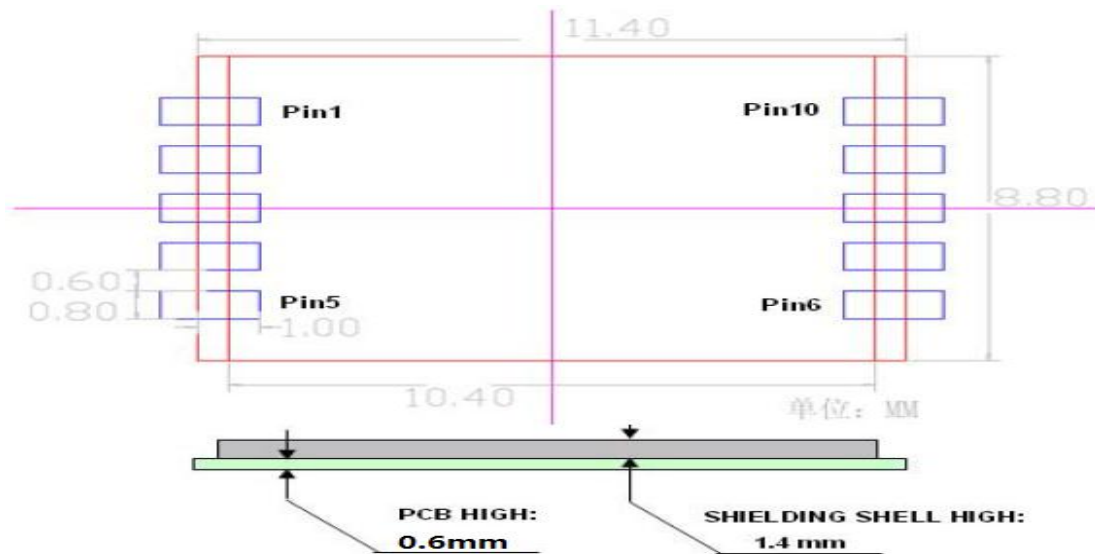

Figure 10: Top view Dimensions

7 Manufacturing, Packaging and Ordering Information

7.1. Assembly and Soldering

EU1010module is intended for SMT assembly and soldering in a Pb-free reflow process on the top side of the PCB. It is suggested that the minimum height of solder paste stencil is 100um to ensure sufficient solder volume. Pad openings of paste mask can be increased to ensure proper soldering and solder wetting over pads. It is suggested that the peak reflow temperature is 235~245° C (for SnAg3.0Cu0.5 alloy). The absolute maximum reflow temperature is 260° C. To avoid damage to the module when it is repeatedly heated, it is suggested that the module should be mounted after reflow soldering for the other side of PCB has been completed. Recommended reflow soldering thermal profile is shown below:

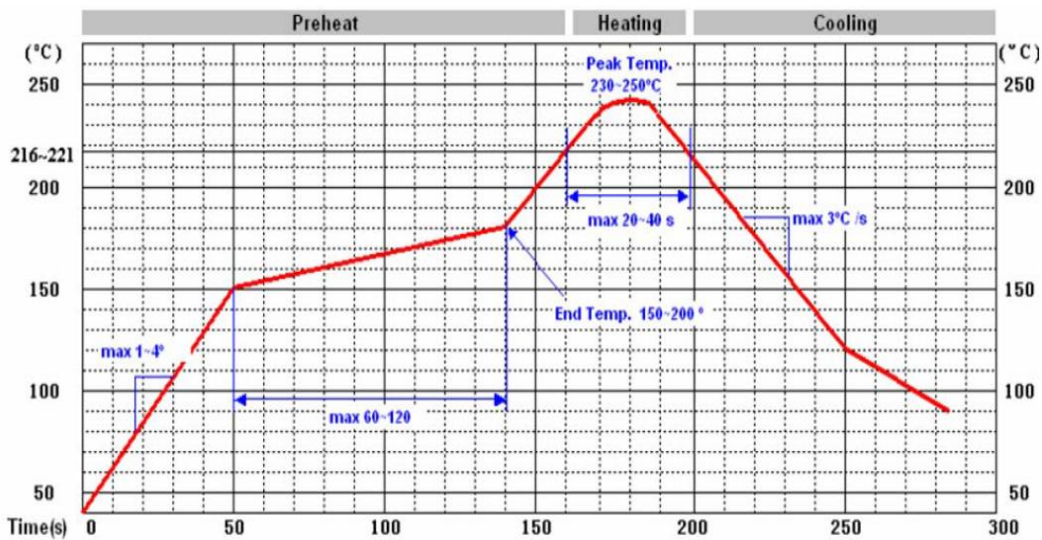

Figure 11: Recommended Reflow Soldering Thermal Profile

7.2. Moisture Sensitivity

EU1010module is sensitive to moisture. To prevent EU1010from permanent damage during reflow soldering, baking before reflow soldering is required in following cases:

- ✧ Humidity indicator card: One or more indicating spots are no longer blue.
- ✧ The seal is opened and the module is exposed to excessive humidity.

EU1010should be baked for 192 hours at temperature 40°C+5°C/-0°C and <5% RH in low-temperature containers, or 24 hours at temperature 125°C±5°C in high-temperature containers. Care should be taken that the plastic tape is not heat resistant. EU1010should be taken out from the tape before preheating; otherwise, the tape maybe damaged by high-temperature heating.

7.3. Tape and Reel Packaging

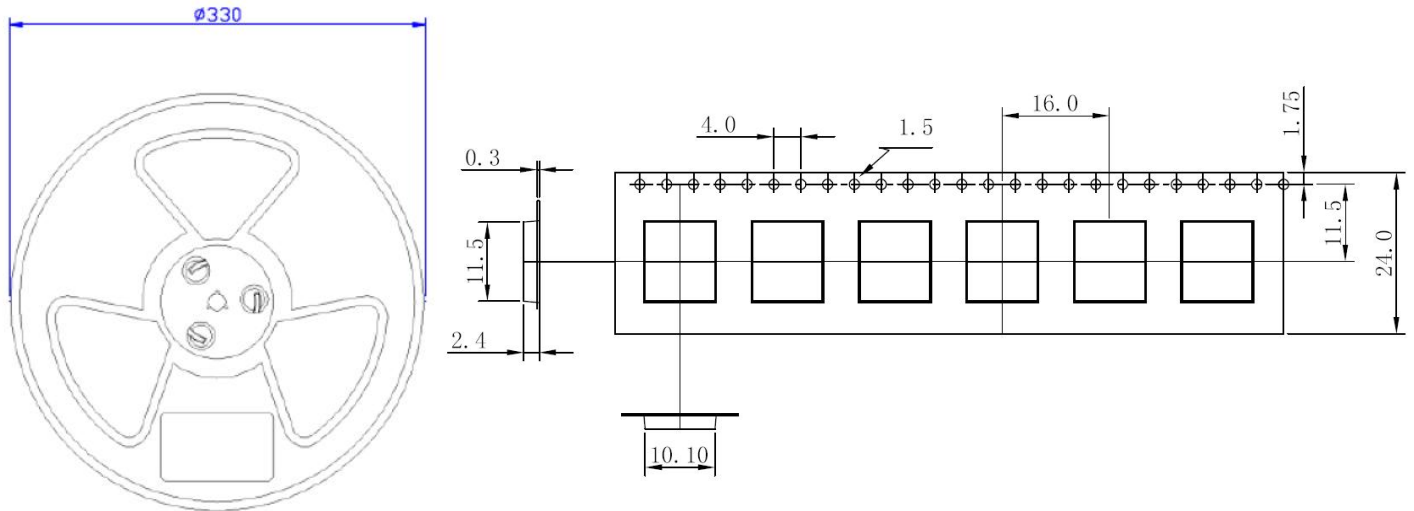

Unit: mm

Quantity per reel: 1000pcs

Length per reel: 16m

Figure 12: Tape and Reel Specifications



Figure 13: Packaging physical Figure

Table 9: Reel Packaging

Model Name	MOQ for MP	Minimum Package: 1000pcs
EU1010	1000pcs	Size: 365mm × 350mm × 53mm N.W: 0.87kg G.W: 1.05kg

8 Appendix References

Table 10: Terms and Abbreviations

Abbreviation	Description
AGPS	Assisted Global navigation satellite system
DGPS	Differential GPS
ESD	Electrostatic Discharge
GPS	Global Positioning System
GPS	Global Navigation Satellite System
GGA	GPS Fix Data
GLL	Geographic Position – Latitude/Longitude
GLONASS	Global Navigation Satellite System
GSA	GPS DOP and Active Satellites
GSV	GPS Satellites in View
HDOP	Horizontal Dilution of Precision
I/O	Input/Output
Kbps	Kilo Bits Per Second
LNA	Low Noise Amplifier
MSAS	Multi-Functional Satellite Augmentation System
MOQ	Minimum Order Quantity
NMEA	National Marine Electronics Association
PDOP	Position Dilution of Precision
PPS	Pulse Per Second
PRN	Pseudo Random Noise Code
QZSS	Quasi-Zenith Satellite System
RHCP	Right Hand Circular Polarization
RMC	Recommended Minimum Specific GPS Data
SBAS	Satellite-based Augmentation System
SAW	Surface Acoustic Wave
SPDT	Single-Pole Double-Throw
TTFF	Time To First Fix

UART	Universal Asynchronous Receiver & Transmitter
VDOP	Vertical Dilution of Precision
VTG	Course over Ground and Ground Speed, Horizontal Course and Horizontal Velocity
WAAS	Wide Area Augmentation System
Inom	Nominal Current
Imax	Maximum Load Current
Vmax	Maximum Voltage Value
Vnom	Nominal Voltage Value
Vmin	Minimum Voltage Value
VIHmax	Maximum Input High Level Voltage Value
VIHmin	Minimum Input High Level Voltage Value
VILmax	Maximum Input Low Level Voltage Value
VILmin	Minimum Input Low Level Voltage Value
VImax	Absolute Maximum Input Voltage Value
VImin	Absolute Minimum Input Voltage Value
VOHmax	Maximum Output High Level Voltage Value
VOHmin	Minimum Output High Level Voltage Value
VOLmax	Maximum Output Low Level Voltage Value
VOLmin	Minimum Output Low Level Voltage Value

9 NMEA 0183 Protocol

The NMEA protocol is an ASCII-based protocol, Records start with a \$ and with carriage return/line feed. GPS specific messages all start with \$GPxxx is a three-letter identifier of the message data that follows. NMEA messages have a check sum, which allows detection of corrupted data transfers.

- ◇ Delin EU1010 supports the following NMEA-0183 messages: \$GPGGA, \$GPGLL, \$GPGSA, \$GPGSV, \$GPRMC and \$GPVTG.

Table 11: NMEA-0183 Output Messages

NMEA Record	DESCRIPTION
GGA	Global positioning system fixed data
GLL	Geographic position—latitude/longitude
GSA	GNSS DOP and active satellites
GSV	GNSS satellites in view
RMC	Recommended minimum specific GNSS data
VTG	Course over ground and ground speed

9.1 GGA-Global Positioning System Fixed Data

\$GPGGA, 161229.487,3723.24751,N, 12158.34160,W, 1,07,1.0,9.0,M.0000*18

Table 12: GGA Data Format

Name	Example	Units	Description
Message ID	\$GPGGA		GGA protocol header
UTC Position	161229.487		hhmmss.sss
Latitude	3723.24571		ddmm.mmmmm
N/S indicator	N		N=north or S=south
Longitude	12158.34160		dddmm.mmmmm
E/W Indicator	W		E=east or W=west
Position Fix Indicator	1		See Table 12-1
Satellites Used	07		Range 0 to 12
HDOP	1.0		Horizontal Dilution of Precision
MSL Altitude	9.0	meters	
Units	M	meters	
Geoids Separation		meters	
Units	M	meters	
Age of Diff.Corr.		second	Null fields when DGPS is not Used
Diff.Ref.Station ID	0000		
Check sum	*18		
<CR> <LF>			End of message termination

Table 12-1: Position Fix Indicators

Value	Description
0	Fix not available or invalid
1	GPS SPS Mode, fix valid
2	Differential GPS, SPS Mode, fix valid
3	GPS PPS Mode, fix valid

9.2 GLL-Geographic Position – Latitude/Longitude

\$GPGLL , 3723.24755, N,12158.34161, W,161229.487, A*2C.

Table 13: GLL Data Format

Name	Example	Units	Description
Message ID	\$GPGLL		GLL protocol header
Latitude	3723.24755		ddmm.mmmmm
N/S Indicator	N		N=north or S=south
Longitude	12158.34161		dddmm.mmmmm
E/W Indicator	W		E=east or W=west
UTC Position	161229.487		hhmmss.sss
Status	A		A=data valid or V=data not valid
Check sum	*2C		
<CR> <LF>			End of message termination

9.3 GSA-GNSS DOP and Active Satellites

\$GPGSA , A, 3, 07, 02, 26,27, 09, 04,15, , , , , 1.8,1.0,1.5*33.

Table 14: GSA Data Format

Name	Example	Units	Description
Message	\$GPGSA		GSA protocol header
Mode 1	A		See Table 14-2
Mode 2	3		See Table 14-1
Satellite Used	07		Sv on Channel 1
Satellite Used	02		Sv on Channel 2
...
Satellite Used			Sv on Channel 12
PDOP	1.8		Position Dilution of Precision
HDOP	1.0		Horizontal Dilution of Precision
VDOP	1.5		Vertical Dilution of Precision
Check sum	*33		
<CR> <LF>			End of message termination

Table 14-1: Mode 1

Value	Description
1	Fix not available
2	2D
3	3D

Table 14-2: Mode 2

Value	Description
M	Manual-forced to operate in 2D or 3D mode
A	Automatic-allowed to automatically switch 2D/3D

9.4 GSV-GPS Satellites in View

\$GPGSV , 2, 1, 07, 07, 79,048, 42, 02, 51,062, 43, 26, 36,256, 42, 27, 27, 138,42*71

\$GPGSV, 2, 2, 07, 09, 23,313, 42, 04, 19, 159, 41, 15,12,041, 42*41.

Table 15: GGA Data Format

Name	Example	Units	Description
Message ID	\$GPGSV		GSV protocol header
Number of Message	2		Range 1 to 3
Message Number	1		Range 1 to 3
Satellites in View	07		
Satellite ID	07		Channel 1(Range 1 to 32)
Elevation	79	degrees	Channel 1(Maximum 90)
Azinmuth	048	degrees	Channel 1(True, Range 0 to 359)
SNR(C/NO)	42	dB/Hz	Range 0 to 99,null when not tracking
...			...
Satellite ID	27		Channel 4(Range 1 to 32)
Elevation	27	degrees	Channel 4(Maximum 90)
Azimuth	138	degrees	Channel 4(True, Range 0 to 359)
SNR(C/NO)	42	dB/Hz	Range 0 to 99, null when not tracking
Check sum	*71		
<CR> <LF>			End of message termination

Depending on the number of satellites tracked multiple messages of GSV data may be required.

9.5 RMC-Recommended Minimum Specific GNSS Data

\$GPRMC, 161229.487, A, 3723.24751, N, 12158.34161, W, 0.13,309.62, 120598,, *10

Table 16: RMC Data Format

Name	Example	Units	Description
Message ID	\$GPRMC		RMC protocol header
UTC Position	161229.487		hhmmss.sss
Status	A		A=data valid or V=data not valid
Latitude	3723.24751		ddmm.mmmmm
N/S Indicator	N		N=north or S=south
Longitude	12158.34161		dddmm.mmmmm
E/W Indicator	W		E=east or W=west
Speed Over Ground	0.13	Knots	
Course Over Ground	309.62	Degrees	True
Ground			
Date	120598		dummy
Magnetic variation		Degrees	E=east or W=west
Check sum	*10		
<CR> <LF>			End of message termination

9.6 VTG-Course Over Ground and Ground Speed

\$GPVTG, 309.62, T, M, 0.13, N, 0.2, K*6E

Table 17: VTG Data Format

Name	Example	Units	Description
Message ID	\$GPVTG		VTG protocol header
Course	309.62	Degrees	Measured heading
Reference	T		True
Course		Degrees	Measured heading
Reference	M		Magnetic
Speed	0.13	Knots	Measured horizontal speed
Units	N		Knots
Speed	0.2	Km/hr	Measured horizontal speed
Units	K		Kilometer per hour
Check sum	*6E		
<CR> <LF>			End of message termination